

**POMPE-MOTORI-DIVISORI DI FLUSSO
AD INGRANAGGI SERIE L**

***GEAR PUMPS-MOTORS
AND FLOW DIVIDERS SERIES L***

**ZAHNRADPUMPEN, -MOTOREN
UND MENGENTEILER BAUREIHE L**

GL016

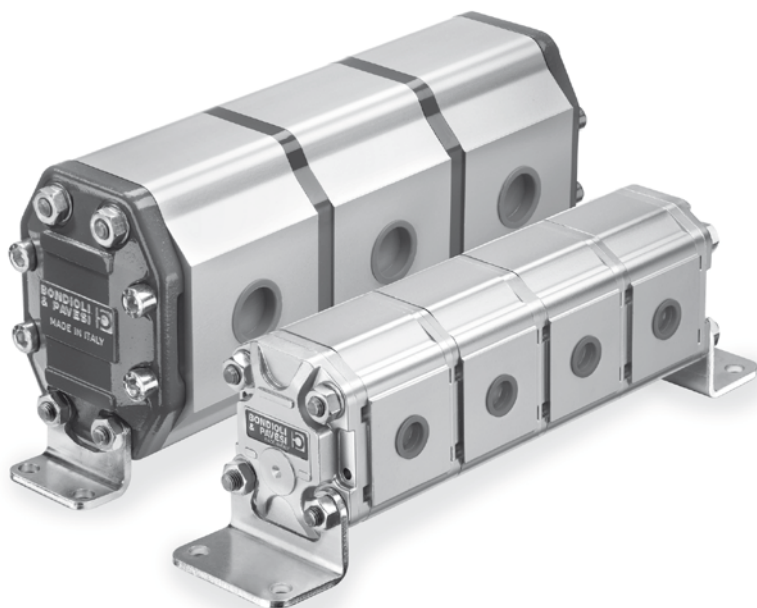

INDICE
INDEX
INHALTSVERZEICHNIS

ISTRUZIONI GENERALI DI IMPIEGO <i>OPERATING INSTRUCTIONS</i> ALLGEMEINE GEBRAUCHSANWEISUNGEN	3
INTRODUZIONE <i>INTRODUCTION</i> EINLEITUNG	4
PROGRAMMA DI PRODUZIONE <i>PRODUCTION RANGE</i> LIEFERPROGRAMM	7
HPL..0	8
HPL..1	12
HPL..2	20
HPL..3	28
HPL..4	36
HPL.. POMPE MULTIPLE <i>MULTIPLE GEAR PUMPS</i> MEHRFACHPUMPEN	42
HPLPT.. POMPE PREDISPOSTE E RELATIVI KIT <i>PUMPS PREPARED FOR ASSEMBLY OF MULTIPLE PUMPS</i> PUMPEN MIT DURCHTRIEB	50
POMPE E MOTORI CON VALVOLE INTEGRATE <i>INTEGRATED VALVES FOR PUMP AND MOTOR</i> PUMPEN UND MOTOREN MIT EINGEBAUTEN VENTILEN	56
POMPE CON VALVOLA PRIORITARIA <i>PRIORITY VALVE PUMPS</i> PUMPE MIT PRIORITÄTSENTIL	58
POMPE LOAD SENSING <i>LOAD SENSING PUMPS</i> LOAD SENSING PUMPE	60
POMPE HIGH-LOW <i>HIGH-LOW PUMPS</i> ZAHNRADPUMPE MIT HIGH-LOW	62
SUPPORTI <i>SPINDLES</i> VORSATZLAGER	64
HPLDF.. DIVISORI DI FLUSSO <i>FLOW DIVIDERS</i> MENGENTEILER	72
RACCORDI E GUARNIZIONI <i>CONNECTORS AND SEALS</i> VERBINDUNGEN UND DICHTUNGEN	89
GIUNTI E SEMIGIUNTI PER SUPPORTI <i>HUBS AND HALF HUBS FOR SPINDLES</i> KUPPLUNGEN UND HALBKUPPLUNGEN FÜR VORSATZLAGER	90

CARATTERISTICHE FUNZIONALI

Le curve caratteristiche rappresentate nel presente catalogo sono tipiche di prodotti di produzione calcolati e testati in laboratorio e non necessariamente rappresentative di ogni unità.

CONSERVAZIONE A MAGAZZINO

I componenti idraulici vanno conservati nel loro imballaggio in luogo asciutto, lontano dall'irraggiamento solare o da sorgenti di calore o di ozono, in un ambiente con temperatura compresa tra -20°C e +50°C.

FLUIDO IDRAULICO

Utilizzare fluidi idraulici definiti dalla norma UNI EN ISO 6743-4 prospetto 1 limitatamente alle seguenti tipologie di fluido:

ISO-L-HL / ISO-L-HM / ISO-L-HR / ISO-L-HV
ISO-L-HS Per fluidi diversi da quelli citati si prega di consultare il nostro servizio tecnico.

TEMPERATURE LIMITE DI FUNZIONAMENTO

Temperatura minima -20°C.
Temperatura massima continua +85°C.
Temperatura massima di picco +100°C.
L'esercizio con fluido a temperatura superiore a +85°C comporta un precoce decadimento delle caratteristiche funzionali delle guarnizioni impiegate. (NBR).

VISCOSITÀ

Deve essere verificata la rispondenza alla viscosità del fluido, richiesta per il corretto funzionamento: minima 10 mm²/s (per brevi periodi), massima 1000 mm²/s (per brevi periodi alla partenza), viscosità raccomandata 15-90 mm²/s.

PRESSIONE DI FUNZIONAMENTO IN ASPIRAZIONE

Pressione massima assoluta:
P min 0,8 bar - P max 2 bar.

PRESSIONE DI DRENAGGIO

Pressione massima assoluta: 2 bar.

GRADO DI FILTRAZIONE

La classe di contaminazione consigliata per pompe e servocomandi è la seguente:
Classe ISO4406 20/18/15 (NAS1638 - 9)

INSTALLAZIONE

Prima di far funzionare i componenti idraulici, assicurarsi che tutto il circuito idraulico sia accuratamente riempito d'olio e disareato. Filtrare l'olio di riempimento in modo da garantire la classe ISO o NAS richiesta. Prevedere nel circuito un sistema di filtraggio che garantisca la classe ISO o NAS richiesta. Avviare l'impianto lentamente a vuoto, facendolo spurgare bene dell'aria residua prima di applicare il carico. Sostituire i filtri dopo le prime 50 ore di lavoro. Sostituire il filtro del circuito idraulico ogni 500 ore di funzionamento. Sostituire il fluido idraulico come da specifiche del fornitore. In caso di mancato funzionamento dei componenti idraulici non insistere inutilmente; riconfermare la corretta esecuzione dell'impianto ed eventualmente contattare il servizio tecnico.

 Operare sempre prestando la massima attenzione agli organi in movimento; non utilizzare indumenti larghi o sciolazzanti.

Non approssimarsi a ruote, cingoli, trasmissioni a catena o ad alberi non adeguatamente protette in movimento, o che potrebbero iniziare a muoversi in qualsiasi istante senza preavviso.

Non svitare e scollegare raccordi e tubi con il motore in moto. Evitare le fughe di olio, per prevenire l'inquinamento ambientale. Non dirigere getti d'acqua direttamente sui componenti idraulici.

HP Hydraulic si solleva da ogni responsabilità riguardante la non osservanza di queste indicazioni e del rispetto delle norme normative di sicurezza vigenti, anche se non contemplate nel presente manuale.

FUNCTIONAL FEATURES

The characteristic curves represented in this catalogue are typical of laboratory calculated and tested production products and do not necessarily represent each unit.

WAREHOUSE STORAGE

The hydraulic components must be kept in their packaging in a dry place, away from sunlight or sources of heat or ozone, at a temperature between -20°C e +50°C

HYDRAULIC FLUID

Use hydraulic fluids defined by standard UNI EN ISO 6743-4 prospectus 1 limited to the following types of fluid:

ISO-L-HL / ISO-L-HM / ISO-L-HR / ISO-L-HV
ISO-L-HS For fluids other than those mentioned please contact our technical support service.

OPERATING LIMIT TEMPERATURES

Minimum temperature -20°C
Maximum continuous temperature +85°C
Maximum peak temperature +100°C
Operating with fluid at temperatures higher than +85°C entails early wear of the functional features of the gaskets used. (NBR)

VISCOSITY

The correspondence of the fluid to the viscosity required for correct operation must be checked:

minimum 10 mm²/s (for short periods),
maximum 1000 mm²/s (for short periods when starting), recommended viscosity 15-90 mm²/s.

INTAKE OPERATING PRESSURE

Maximum absolute value:
P min 0.8 bar - P max 2 bar

DRAIN PRESSURE

Maximum absolute pressure: 2 bar

FILTRING DEGREE

The recommended contamination class for pumps and servovalves is the following:
Class ISO4406 20/18/15 (NAS1638 - 9)

INSTALLATION

Before operating the hydraulic components, make sure that the entire hydraulic circuit is completely filled with oil and degaired.

Filter the filling oil in order to guarantee the required ISO or NAS class. Provide a filtering system in the circuit which guarantees the required ISO or NAS class. Start the system slowly unloaded, properly purging residual air before applying the load. Replace the filters after the first 50 hours of work. Replace the filter of the hydraulic circuit every 500 hours of work. Replace the hydraulic filter according to the supplier's specifications.

If the hydraulic components do not work, do not insist in trying them to no avail; recheck the correct execution of the system and contact the technical service if needed.

 Always pay the utmost attention to moving parts when operating; do not wear wide or loose clothing.

Do not approach wheels, belts, chain or shaft transmissions which are inadequately protected or in movement or which could start moving suddenly without forewarning.

Do not unscrew or disconnect fittings and pipes with the motor running. Avoid oil leakage to prevent environmental pollution. Do not spray water directly on hydraulic components.

HP Hydraulic will not be held liable for failure to comply with these indications and with safety standards in force even if not considered in this manual.

FUNKTIONSEIGENSCHAFTEN

In die dem vorliegenden Katalog dargestellten Kennlinien sind typisch für Produkte, die im Labor berechnet und getestet wurden und sind nicht unbedingt für jede Einheit charakteristisch.

LAGERUNG

Die hydraulischen Komponenten sind in ihrer Verpackung in einem trockenen Raum, fern von Sonneneinstrahlung und Wärme- oder Ozonquellen, bei einer Umgebungstemperatur zwischen -20°C und +50°C aufzubewahren.

HYDRAULIKFLUID

Es müssen Hydraulikflüssigkeiten verwendet werden, die der Norm UNI EN ISO 6743-4 Übersicht 1 entsprechen, beschränkt auf die folgenden Fluidarten:

ISO-L-HL / ISO-L-HM / ISO-L-HR / ISO-L-HV/ISO-L-HS. Für andere als die angegebenen Flüssigkeiten wird gebeten, unseren technischen Kundendienst zu kontaktieren.

GRENZWERTE BETRIEBSTEMPERATUREN

Mindesttemperatur -20°C
Höchsttemperatur (durchgehend) +85°C
Höchsttemperatur (Spitzenwert) +100°C
Der Betrieb mit dem Fluid bei einer Temperatur über +85°C führt zu einem vorzeitigen Verfall der Funktionseigenschaften der verwendeten Dichtungen. (NBR)

VISKOSITÄT

Es ist zu überprüfen, dass die Viskosität des Fluids für den einwandfreien Betrieb geeignet ist: mindestens 10 mm²/s (über kurze Zeiträume), höchstens 1000 mm²/s (über kurze Zeiträume beim Starten), empfohlene Viskosität 15-90 mm²/s.

BETRIEBSDRUCK EINGANGSSEITIG

Absoluter Höchstdruck:
P min 0,8 bar - P max 2 bar

ABLASSDRUCK

Absoluter Höchstdruck: 2 bar

FILTRATIONSGRAD

Für Pumpen und Servosteuervorgaben wird folgende Reinheitsklasse empfohlen:
Klasse ISO4406 20/18/15 (NAS1638 - 9)

INSTALLATION

Vor Inbetriebnahme der hydraulischen Komponenten, ist sicherzustellen, dass der gesamte Hydraulikkreis entsprechend mit Öl befüllt und entlüftet wurde. Das Öl für die Befüllung ist so zu filtern, dass die Einhaltung der geforderten ISO- oder NAS-Klassen gewährleistet werden kann. Im Kreislauf ist ein Filtrationssystem vorzusehen, das die Einhaltung der geforderten ISO- oder NAS-Klassen gewährleistet. Die Anlage langsam leer in Betrieb nehmen und vor Lastaufbringung die vorhandene Restluft vollständig entweichen lassen. Die Filter nach den ersten 50 Betriebsstunden auswechseln. Den Filter des Hydraulikkreises jeweils nach 500 Betriebsstunden auswechseln. Für den Austausch des Hydraulikfilters sind die Spezifikationen des Herstellers zu berücksichtigen. Bei einer Funktionsstörung der hydraulischen Komponenten den Betrieb unterbrechen, die korrekte Ausführung der Anlage überprüfen und gegebenenfalls den Technischen Kundendienst kontaktieren.

 Bei Durchführung der Tätigkeiten immer besonders auf in Bewegung befindliche Elemente achten; keine weite oder flatternde Kleidung tragen. Sich niemals Rädern, Raupenketten, Ketten- oder Wellenantrieben nähern, die nicht ausreichend geschützt und in Bewegung sind bzw. sich jederzeit ohne Vorankündigung in Bewegung setzen könnten. Niemals Verbindungsstücke und Rohre bei laufendem Motor lösen und entfernen. Zur Vorbeugung von Umweltverschmutzungen sind Öllecksagen zu vermeiden. Niemals Wasserstrahlen direkt auf die Hydraulikkomponenten richten.

Im Fall der Nichtbeachtung dieser Anweisungen und der gültigen Sicherheitsnormen, auch wenn diese im vorliegenden Handbuch nicht angeführt, lehnt HP Hydraulic jegliche Verantwortung ab.

INTRODUZIONE INTRODUCTION EINLEITUNG

Tra le unità idrostatiche le pompe e motori ad ingranaggi sono tra le più prodotte ed utilizzate. La robustezza della concezione, il favorevole rapporto prezzo/prestazioni, la semplicità di installazione, la possibilità di soluzioni personalizzate, l'integrazione con componenti di controllo (valvole) sono alcuni dei punti caratterizzanti questi prodotti.

L'offerta HP Hydraulic si innesta su una pluridecennale e consolidata tradizione di sviluppo e produzione di unità ad ingranaggi con spirito innovativo nel design e nei processi produttivi.

Questo permette di offrire una gamma di pompe ad ingranaggi con corpo in alluminio suddivisa in modo ottimale in gruppi e cilindrate (da 0,19 a 90 cc/giro) con la possibilità di varianti ad hoc e con prestazioni che permettono ogni tipo d'impiego.

Le pompe HP Hydraulic della serie L sono prodotte in cinque differenti gruppi dimensionali 0,1,2, 3, 4, all'interno dei quali vengono ottenute le differenti cilindrate.

Una gamma completa di flange, estremità d'albero e la possibilità di ottenere pompe multiple e/o con valvole integrate nel coperchio posteriore completano la gamma di produzione.

Gear pumps and motors are among the most popularly produced and utilized hydrostatic units. Some of their many characteristics are: robust design, profitable price/performance ratio, easy installation, suitability for customized solutions, possible integration with control devices (valves).

HP Hydraulic offers decades of well consolidated experience in the development and production of gear units with a constant approach towards innovation of design and of manufacturing process.

This same experience enables us today to offer a gear pumps range with aluminium body, grouped according to their capacity (from 0,19 to 90 cc/rev.), whose main features can be devised and varied to best respond to customer's requirements and whose performance permits use in any kind of application.

HP Hydraulic series L pumps are supplied in five groups, different in size (0,1,2,3,4). Various capacities will be determined within each group.

The series of products is even further completed with a full range of flanges, shaft ends, and available multiple pumps with or without valves integrated into the back cover.

Zahnradpumpen und -motoren gehören zu den meistgebauten und gängigsten hydrostatischen Maschinen:

Die robuste Bauweise, das günstige Preis-/Leistungsverhältnis, der einfache Einbau, die Möglichkeit individueller Lösungen, die Kombination mit Steuerungskomponenten (Ventile) sind nur einige der Vorzüge, durch die sich diese Produkte auszeichnen.

Das Angebot von HP Hydraulic beruht auf einer jahrzehntelangen und bewährten Tradition in Entwicklung und Produktion von Zahnradeneinheiten mit stark innovativem Gehalt in Design und Produktionsprozessen.

Dadurch sind wir in der Lage, ein Programm von Zahnradpumpen mit Aluminiumgehäuse für jede Anwendung anzubieten, das optimal in Baugruppen und Hubvolumen (von 0,19 bis 90 ccm/U) sowie speziell entwickelte, kundenspezifische Varianten gegliedert ist.

Die Pumpen HP Hydraulic Baureihe L sind in fünf verschiedenen Baugrößen erhältlich – nämlich 0, 1, 2, 3, 4 – innerhalb derer die verschiedenen Hubvolumen lieferbar sind. Das Produktionsprogramm wird ergänzt durch ein komplettes Angebot von Flanschen und Wellen, und durch die Möglichkeit, Mehrfachpumpen und/oder Pumpen mit Zusatzventilen im Enddeckel auszustatten.

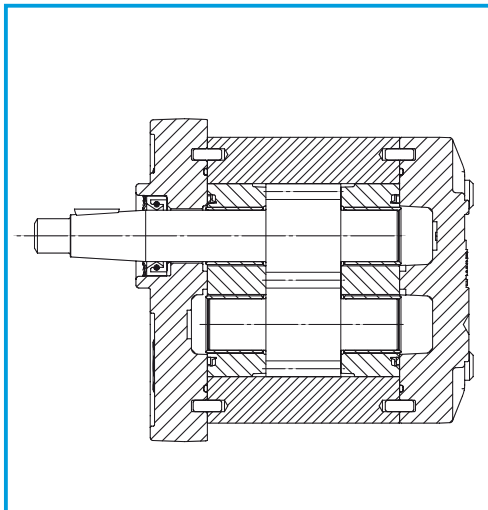

DEFINIZIONE DEL VERSO DI ROTAZIONE GUARDANDO L'ALBERO DI TRASCINAMENTO
DEFINITION OF ROTATION LOOKING AT THE DRIVE SHAFT
BESTIMUNG DER DREHRICHTUNG MIT BLICK AUF DIE ANTRIEBSWELLE

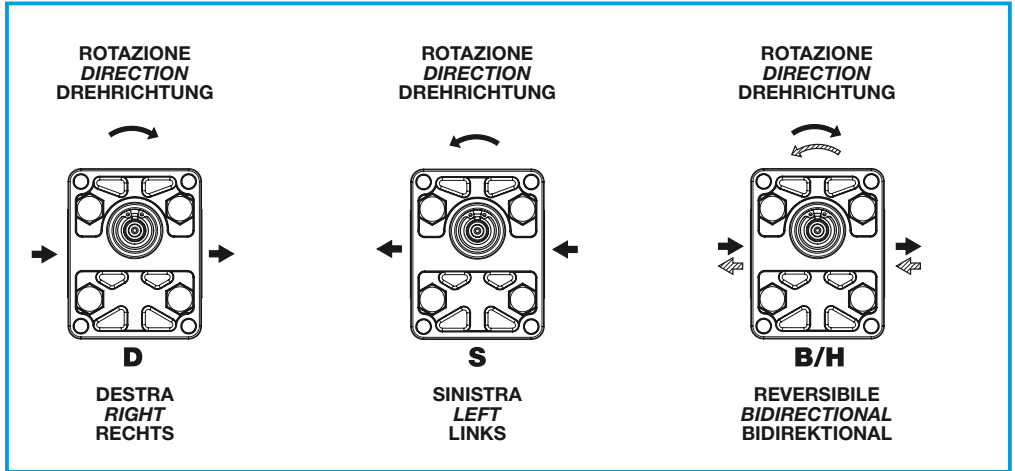

FORMULE INERENTI A POMPE E MOTORI
FORMULAS FOR PUMPS AND MOTORS
FORMELN FÜR PUMPEN UND MOTOREN

POMPA PUMP PUMPE				MOTORE MOTOR MOTOR			
$Q = c \cdot \eta_v \cdot n \cdot 10^{-3} \quad [l/min]$				$Q = \frac{c \cdot n \cdot 10^{-3}}{\eta_v} \quad [l/min]$			
$M = \frac{\Delta p \cdot c}{62,83 \cdot \eta_m} \quad [Nm]$				$M = \frac{\Delta p \cdot c \cdot \eta_m}{62,83} \quad [Nm]$			
$P = \frac{\Delta p \cdot c \cdot n}{600 \cdot 1000 \cdot \eta_t} \quad [kW]$				$P = \frac{\Delta p \cdot c \cdot n \cdot \eta_t}{600 \cdot 1000} \quad [kW]$			
Q	[l/min]	Portata Flow rate Durchfluß	c	[cm ³ /giro]	Cilindrata Displacement Fördervolumen	η_v	Rendimento volumetrico Volumetric efficiency Volumetrisch Leistungsfähigkeit
M	[Nm]	Coppia Torque Drehmoment	n	[min ⁻¹]	nr. giri Speed Drehzahl	η_m	Rendimento meccanico Mechanical efficiency Mechanisch Leistungsfähigkeit
P	[kW]	Potenza Power Leistung	Δp	[bar]	Pressione Pressure Druck	$\eta_t = \eta_v \cdot \eta_m$	Rendimento totale Overall efficiency Gesamt Leistungsfähigkeit

DEFINIZIONE DELLE PRESSIONI
PRESSURE DEFINITION
DRUCKBESTIMMUNGEN

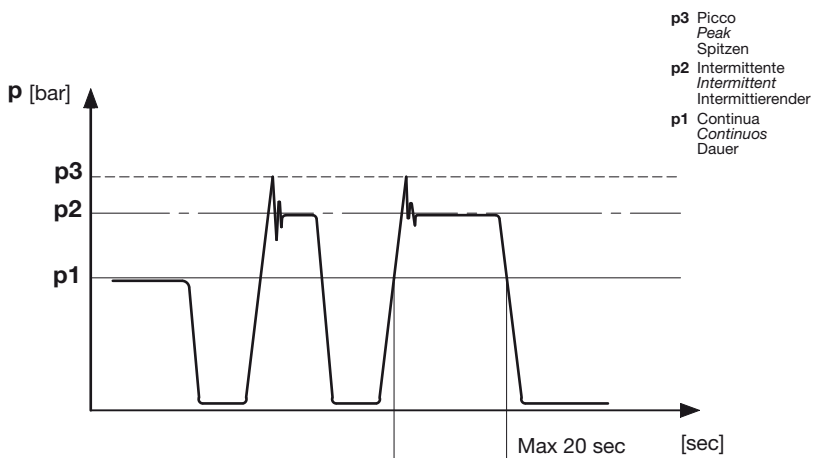

COPPIE DI SERRAGGIO VITI
SCREW TIGHTENING TORQUE
SCHRAUBENANZUGSMOMENT

Codice Code Code	Tipo vite Screw type Schraube Typ	Coppia min Min Torque Min Drehmoment [Nm]	Coppia max Max Torque Max Drehmoment [Nm]
HPL..0	M5	5	5.5
HPL..1	M8	20	25
HPL..2	M10	43	45
HPL..2	Versione SG SG Version SG Version	60	65
HPL..3	M10	48	50
HPL..3	Versione SG SG Version SG Version	48	50
HPL..4	Versione SG SG Version SG Version	48	50

**POMPE
 PUMPS
 PUMPEN**

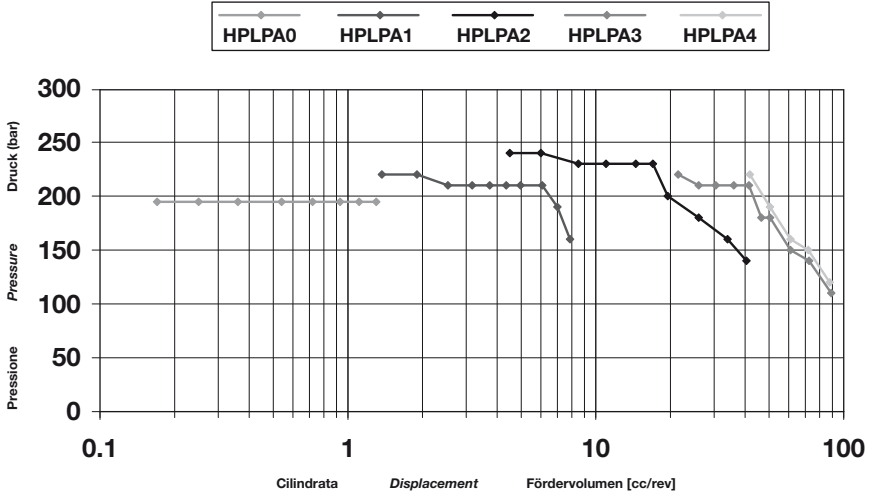

**MOTORI
 MOTORS
 MOTOREN**

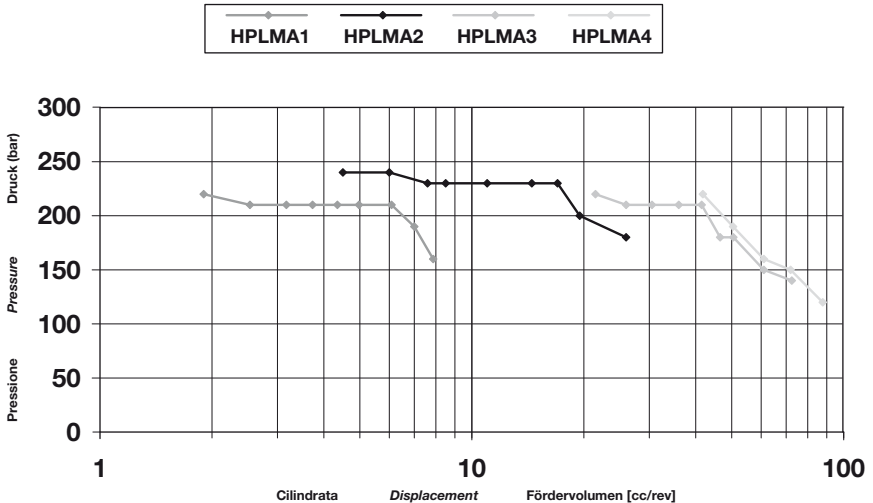

DATI TECNICI TECHNICAL DATA TECHNISCHE MERKMALE

GRUPPO GROUP BAUREIHE	TIPO TYPE TYP	CILINDRATA TEORICA NOMINAL DISPLACEMENT FÖRDERVOLUMEN (TM)		CONTINUA CONTINUOUS DAUER		PRESSIONE PRESSURE DRUCK		PICCO PEAK SPITZEN		VELOCITÀ DI ROTAZIONE SPEED DREHZÄHL		MASSA WEIGHT GEWICHT	
		cm ³	in ³	bar	psi	bar	psi	bar	psi	MAX	MIN	kg	lbs
0	01	0,19	0,01	190	2756	210	3046	230	3336	6000	1000	0,39	0,86
	02	0,26	0,02	190	2756	210	3046	230	3336			0,39	0,86
	03	0,38	0,02	190	2756	210	3046	230	3336			0,40	0,88
	05	0,51	0,03	190	2756	210	3046	230	3336			0,40	0,88
	06	0,64	0,04	190	2756	210	3046	230	3336			0,41	0,90
	09	0,88	0,06	190	2756	210	3046	230	3336			0,42	0,93
	10	1,00	0,07	190	2756	210	3046	230	3336	0,43	0,95		
12	1,25	0,08	190	2756	210	3046	230	3336	5000	0,44	0,97		

DIAGRAMMA PORTATE DIAGRAMS KENNLINIEN

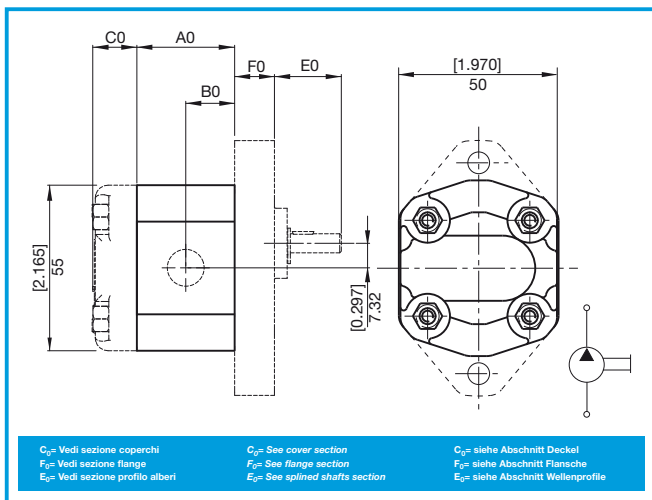
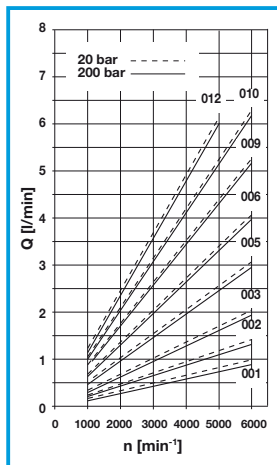

C₀: Vedi sezione coperschi
F₀: Vedi sezione flange
E₀: Vedi sezione profilo albero

C₀: See cover section
F₀: See flange section
E₀: See splined shafts section

C₀: siehe Abschnitt Deckel
F₀: siehe Abschnitt Flansche
E₀: siehe Abschnitt Wellenprofile

DIMENSIONI SIZE ABMESSUNGEN

GRUPPO GROUP BAUREIHE	TIPO TYPE TYP	A ₀		B ₀	
		mm	in	mm	in
0	01	23,0	0,906	11,5	0,453
	02	24,0	0,945	12,0	0,472
	03	26,0	1,024	13,0	0,512
	05	32,0	1,260	16,0	0,630
	06	33,0	1,299	16,5	0,649
	09	35,0	1,378	17,5	0,689
	10	36,0	1,417	18,0	0,709
12	38,0	1,496	19,0	0,748	



**COPERCHI
COVERS
DECKEL**

HPL..0

ST

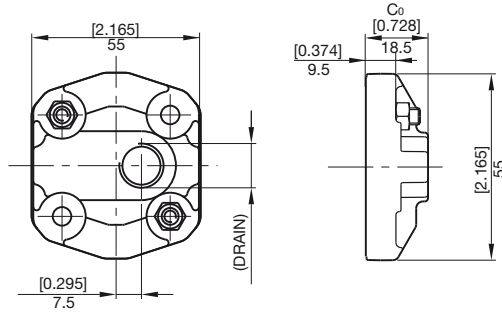

**FLANGE
FLANGES
FLANSCH**

A

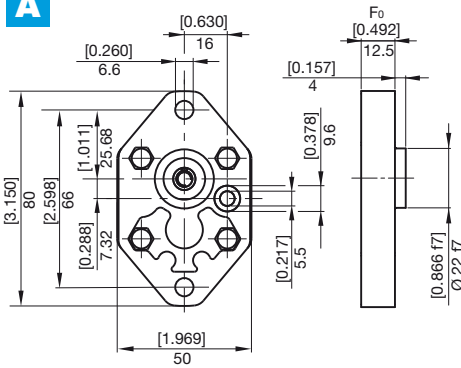

B

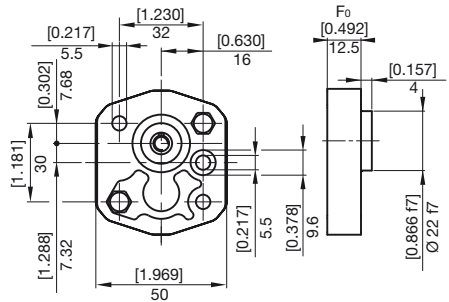

**PROFILO ALBERI
SPLINE SHAFTS
WELLENPROFIE**

A

**COPPIA MAX
MAX TORQUE
MAX DREHMOMENT**

8,5 N•m

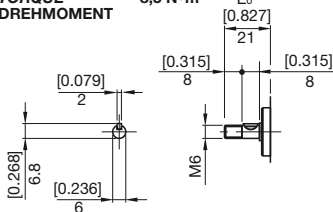

B

**COPPIA MAX
MAX TORQUE
MAX DREHMOMENT**

10 N•m

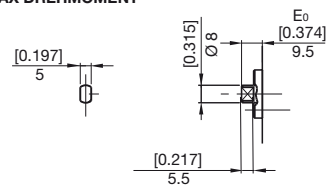

**BOCCH
PORTS
ANSCHLÜSSE**

HPL..0

G LATERALE
LATERAL
SEITLICH
T POSTERIORE
REAR
HINTEN

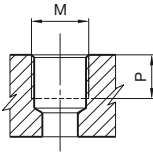

TIPO TYPE TYP	M	P	
		Nm	mm in
* G1	1/8" GAS BSPP	8	8 0,31
G2	1/4" GAS BSPP	17	9 0,35
T2	1/4" GAS BSPP	17	12 0,47

* Drenaggio * Drain Port * Lecköl

H ANTERIORE
FRONT
VORNE

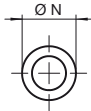





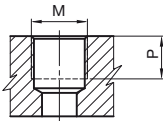



TIPO TYPE TYP	FRONTALE SEAL FRONTAL	N	
		mm	in
H0	OR 8,73 x 1,78	9,6	0,38

M LATERALE
LATERAL
SEITLICH



TIPO TYPE TYP	M	P	
		Nm	mm in
M0	M10x1	10	9 0,35

**COMBINAZIONI
COMBINATIONS
KOMBINATIONEN**

ESTREMITÀ ALBERO SHAFT PROFIL WELLE ENDE	FLANGE FLANGE FLANSCH	
	A 	B 
A 	<input checked="" type="checkbox"/>	<input type="checkbox"/>
B 	<input checked="" type="checkbox"/>	<input checked="" type="checkbox"/>
BOCCH PORTS ANSCHLÜSSE		
M 	<input checked="" type="checkbox"/>	<input checked="" type="checkbox"/>
G 	<input checked="" type="checkbox"/>	<input checked="" type="checkbox"/>
T 	<input checked="" type="checkbox"/>	<input checked="" type="checkbox"/>
H 	<input checked="" type="checkbox"/>	<input checked="" type="checkbox"/>



ISTRUZIONI PER L'ORDINAZIONE
ORDERING INSTRUCTIONS
BESTELLANLEITUNG

HPL..0



SERIE
SERIES
SERIE

PRODOTTO
PRODUCT
PRODUKT
PA - Pompa singola
PA - Single Pump
PA - Einfachpumpe

GRUPPO
GROUP
BAUGRÖSSE
0

CILINDRATA
DISPLACEMENT
FÖRDERVOLUMEN
01 - 0,19
02 - 0,26
03 - 0,38
05 - 0,51
06 - 0,64
09 - 0,88
10 - 1,00
12 - 1,25

SENSO DI ROTAZIONE
ROTATION
DREHRICHTUNG
S - Antioraria/sinistra
D - Oraria/destra
B - Bidirezionale drenaggio esterno posteriore
S - Counterclockwise
D - Clockwise
B - Reversible rear. drain. pont.
S - Linkslauf
D - Rechtslauf
B - reversibel, Lecköl extern, Anschluß hinten

COPERCHI
COVERS
DECKEL
ST - Standard
Standard
Standard

GUARNIZIONI
SEALS
DICHTUNGEN
B - NBR
V - Viton

BOCCHES STANDARD
STANDARD PORT
STANDARD ANSCHLÜSSE

<u>01...03</u>	<u>05...06</u>	<u>09...12</u>	<u>DRAIN</u>
M0M0	M0M0	-	G1
-	G2G2	G2G2	G1
T2H0	T2H0	T2H0	-
M0H0	M0H0	-	-
-	G2H0	G2H0	-

ESTREMITÀ D'ALBERO
SHAFT PROFIL
WELLENENDE
A - Cilindrico Ø6
Parallel Shaft Ø6
zylindrisch Ø6
B - Dente frontale
Tang drive
Profil

FLANGIA
FLANGE
FLANSCH
A - Standard
Standard
Standard
B - Quadrata
Square
quadratisch

HPL ..1

POMPE E MOTORI AD INGRANAGGI GEAR PUMPS AND MOTORS ZAHNRADPUMPEN UND -MOTOREN

HPL PA1

POMPE AD INGRANAGGI GEAR PUMPS ZAHNRADPUMPEN

DATI TECNICI TECHNICAL DATA TECHNISCHE MERKMALE



DIAGRAMMA PORTATE DIAGRAMS KENNLINIEN

GRUPPO GROUP BAUREIHE	TIPO TYPE TYP	CILINDRATA TEORICA NOMINAL DISPLACEMENT FÖRDERVOLUMEN (TM)		PRESSIONE PRESSURE DRUCK INTERMITTENTE INTERMITTIERENDER				VELOCITÀ DI ROTAZIONE SPEED DREHZAHL		MASSA WEIGHT GEWICHT			
		cm ³	in ³	CONTINUA CONTINUOUS DAUER		PICCO PEAK SPITZEN		MAX	MIN	kg	lbs		
				bar	psi	bar	psi						
1	14	1,37	0,08	220	3191	260	3771	280	4061	3500	700	0,90	1,98
	19	1,90	0,12	220	3191	260	3771	280	4061			0,95	2,09
	24	2,53	0,15	210	3046	250	3626	260	3771			0,95	2,09
	31	3,17	0,19	210	3046	250	3626	260	3771			0,95	2,09
	36	3,73	0,23	210	3046	250	3626	260	3771			1,05	2,31
	44	4,35	0,27	210	3046	250	3626	260	3771			1,05	2,31
	48	4,97	0,30	210	3046	250	3626	260	3771	1,05	2,31		
	60	6,08	0,37	210	3046	250	3626	260	3771	1,20	2,65		
	70	7,00	0,43	190	2756	210	3046	230	3336	1,20	2,65		
	80	7,87	0,48	160	2321	180	2611	200	2901	1,20	2,65		

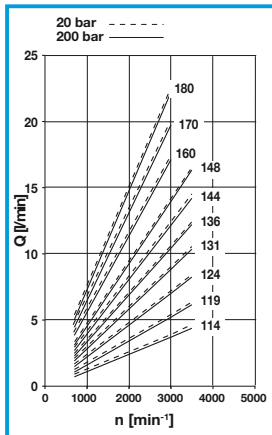

HPL MA1

MOTORI AD INGRANAGGI GEAR MOTORS ZAHNRADMOTOREN

DATI TECNICI TECHNICAL DATA TECHNISCHE MERKMALE



DIAGRAMMA PORTATE DIAGRAMS KENNLINIEN

GRUPPO GROUP BAUREIHE	TIPO TYPE TYP	CILINDRATA TEORICA NOMINAL DISPLACEMENT FÖRDERVOLUMEN (TM)		PRESSIONE PRESSURE DRUCK INTERMITTENTE INTERMITTIERENDER				VELOCITÀ DI ROTAZIONE SPEED DREHZAHL		MASSA WEIGHT GEWICHT			
		cm ³	in ³	CONTINUA CONTINUOUS DAUER		PICCO PEAK SPITZEN		MAX	MIN	kg	lbs		
				bar	psi	bar	psi						
1	19	1,90	0,12	220	3191	260	3771	280	4061	4000	700	0,95	2,09
	24	2,53	0,15	210	3046	250	3626	260	3771			0,95	2,09
	31	3,17	0,19	210	3046	250	3626	260	3771			0,95	2,09
	36	3,73	0,23	210	3046	250	3626	260	3771			1,05	2,31
	44	4,35	0,27	210	3046	250	3626	260	3771			1,05	2,31
	48	4,97	0,30	210	3046	250	3626	260	3771			1,05	2,31
	60	6,08	0,37	210	3046	250	3626	260	3771	1,20	2,65		
	70	7,00	0,43	190	2756	210	3046	230	3336	1,20	2,65		
	80	7,87	0,48	160	2321	180	2611	200	2901	1,20	2,65		

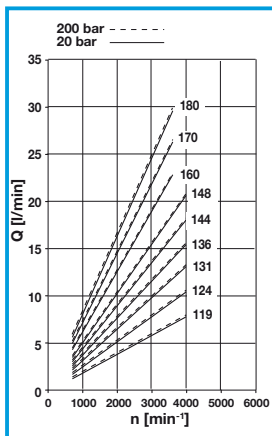



**DIMENSIONI
SIZE
ABMESSUNGEN**

HPL..1

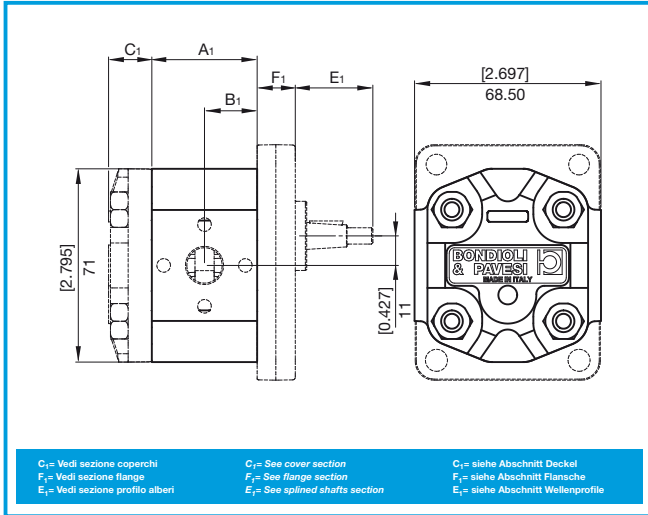

**DIMENSIONI
SIZE
ABMESSUNGEN**

GRUPPO GROUP BAUFORME	TIPO TYPE TYP	A ₁		B ₁	
		mm	in	mm	in
1	14	38,70	1,524	19,4	0,762
	19	38,70	1,524	19,4	0,762
	24	38,70	1,524	19,4	0,762
	31	38,70	1,524	19,4	0,762
	36	45,35	1,785	22,7	0,893
	44	45,35	1,785	22,7	0,893
	48	45,35	1,785	22,7	0,893
	60	56,05	2,207	28,0	1,103
	70	56,05	2,207	28,0	1,103
	80	56,05	2,207	28,0	1,103

**COPERCHI
COVERS
DECKEL**

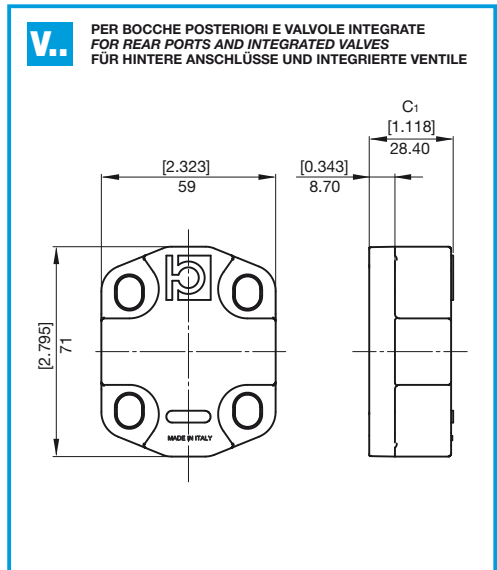
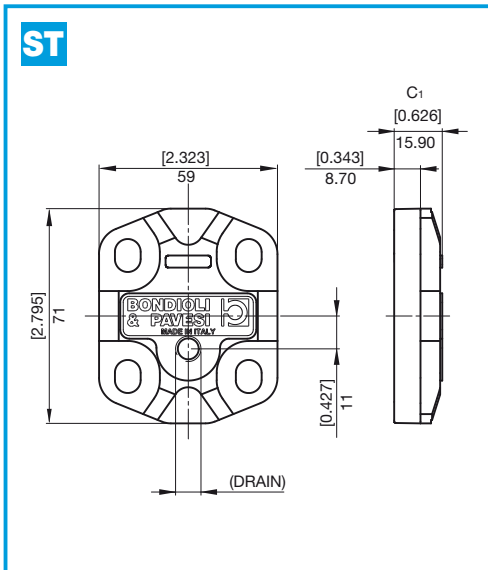

D

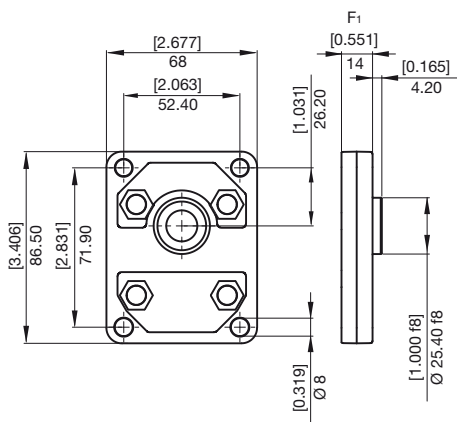

E

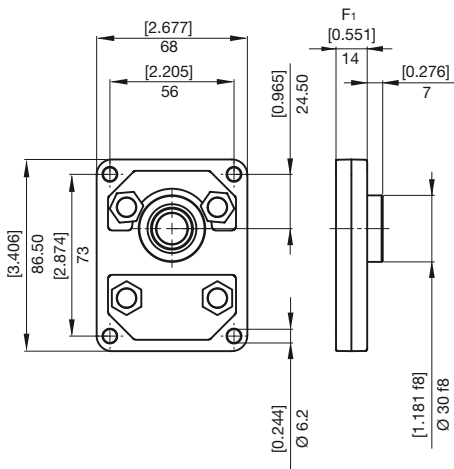

G

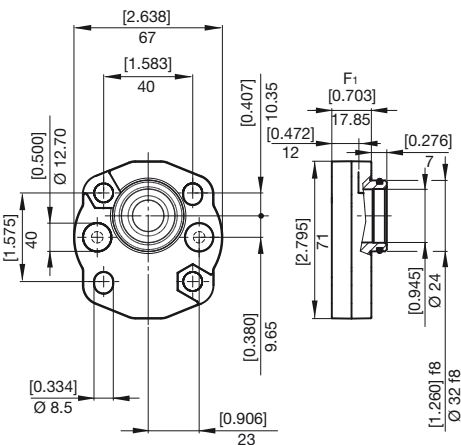

H

Versione senza oring sul centraggio
Without oring on centering version
Version ohne O-Ring auf der Zentrierung

J

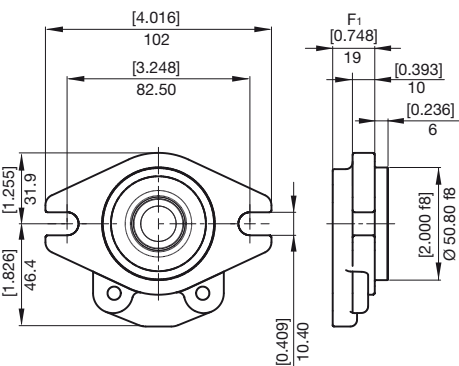



**PROFILO ALBERI
SPLINE SHAFTS
WELLENPROFILE**

HPL..1

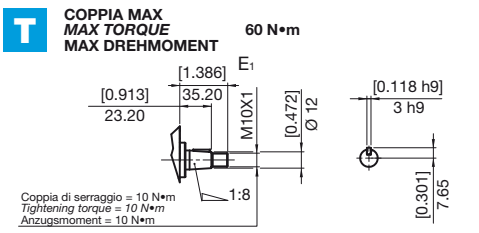
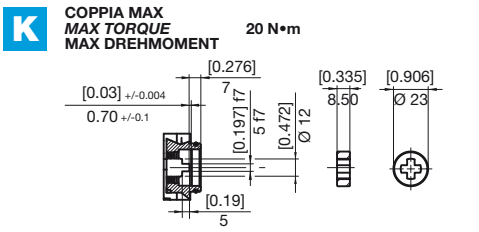
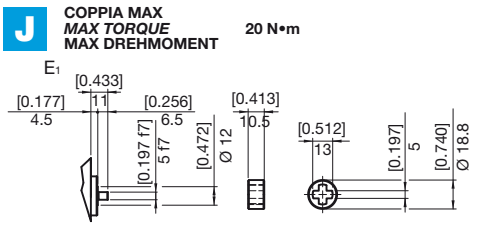
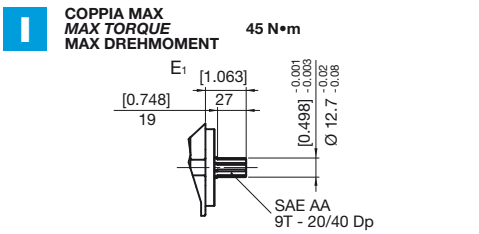
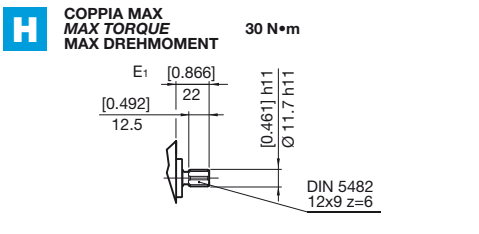
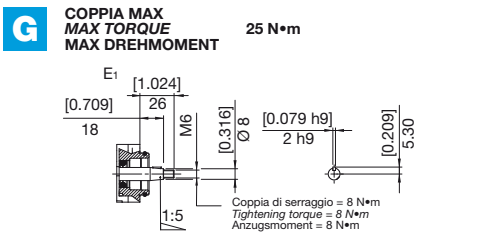
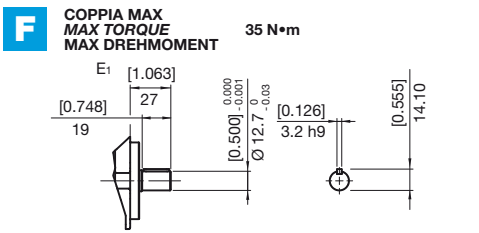
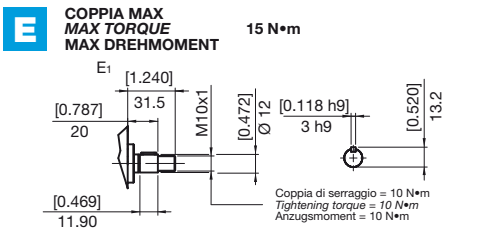
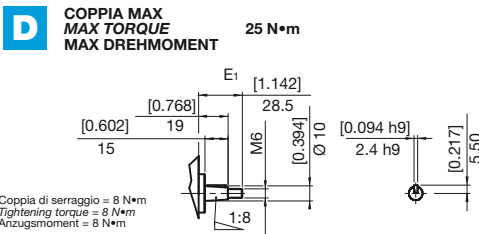

**BOCCHE
PORTS
ANSCHLÜSSE**

HPL..1

E LATERALE
LATERAL
SEITLICH

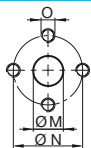

TIPO TYPE TYP	M		N		O	
	mm	in	mm	in		Nm
E2	13	0,51	26	1,02	M5	6
E3	13	0,51	30	1,18	M6	10

G LATERALE
LATERAL
SEITLICH
T POSTERIORE
REAR
HINTEN

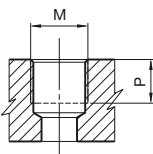

TIPO TYPE TYP		M		P	
		Nm	mm	in	
* G2	1/4" GAS BSPP	17	12	0,47	
G3	3/8" GAS BSPP	38	12	0,47	
G4	1/2" GAS BSPP	50	14,5	0,57	
T3	3/8" GAS BSPP	38	12	0,47	
T4	1/2" GAS BSPP	40	14,5	0,57	

X LATERALE
LATERAL
SEITLICH

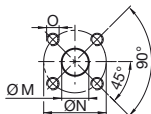

TIPO TYPE TYP	M		N		O	
	mm	in	mm	in		Nm
X3	13	0,51	30	1,18	M6	10

M LATERALE
LATERAL
SEITLICH

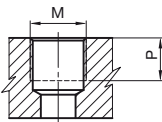

TIPO TYPE TYP	M	P	
		Nm	mm in
* M1	M12x1,5	15	12 0,47
M2	M14x1,5	17	12 0,47
M4	M18x1,5	40	14,5 0,57

H ANTERIORE
FRONT
VORNE

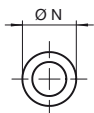

TIPO TYPE TYP	FRONTALE SEAL FRONTAL	N	
		mm	in
H1	OR 9,25 x 1,78	12,7	0,50

U LATERALE
LATERAL
SEITLICH
C POSTERIORE
REAR
HINTEN

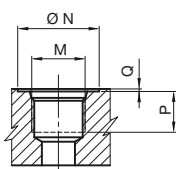

TIPO TYPE TYP	DIMENSIONE SIZE GRÖSSE	N		P		Q		M	
		mm	in	mm	in	mm	in		Nm
* U2	1/4"	21	0,83	12	0,47	0,3	0,01	7/16-20 UNF	17
U3	3/8"	25	0,98	13	0,51	0,3	0,01	9/16-18 UNF	25
U4	1/2"	30	1,18	15	0,59	0,3	0,01	3/4-16 UNF	47
C3	3/8"	25	0,98	13	0,51	0,3	0,01	9/16-18 UNF	25
C4	1/2"	30	1,18	15	0,59	0,3	0,01	3/4-16 UNF	47

* Drenaggio













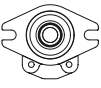





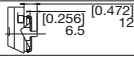

* Drain Port

* Lecköl



**COMBINAZIONI
COMBINATIONS
KOMBINATIONEN**

HPL..1

ESTREMITÀ ALBERO SHAFT PROFIL WELLENENDE		FLANGE FLANGE FLANSCHÉ			
		D 	E 	H G 	J 
D 	<input checked="" type="checkbox"/>	<input checked="" type="checkbox"/>			
E 	<input checked="" type="checkbox"/>	<input checked="" type="checkbox"/>			
F 				<input checked="" type="checkbox"/>	
G 			<input checked="" type="checkbox"/>		
H 	<input checked="" type="checkbox"/>				
I 				<input checked="" type="checkbox"/>	
J 	<input checked="" type="checkbox"/>				
K 			<input checked="" type="checkbox"/>		
T 	<input checked="" type="checkbox"/>	<input checked="" type="checkbox"/>			
BOCCHÉ PORTS ANSCHLÜSSE					
E 	<input checked="" type="checkbox"/>	<input checked="" type="checkbox"/>			
G 	<input checked="" type="checkbox"/>	<input checked="" type="checkbox"/>	<input checked="" type="checkbox"/>	<input checked="" type="checkbox"/>	
X 	<input checked="" type="checkbox"/>	<input checked="" type="checkbox"/>	<input checked="" type="checkbox"/>		
M 			<input checked="" type="checkbox"/>		
T 			<input checked="" type="checkbox"/>		
H 			<input checked="" type="checkbox"/>		
U 				<input checked="" type="checkbox"/>	
C 				<input checked="" type="checkbox"/>	

Questa pagina è intenzionalmente bianca
This page is intentionally blank
Diese Seite ist bewusst frei gelassen



ISTRUZIONI PER L'ORDINAZIONE
ORDERING INSTRUCTIONS
BESTELLANLEITUNG

HPL..1



SERIE
SERIES
SERIE

PRODOTTO
PRODUCT
PRODUKT

MA - Motore
PA - Pompa singola
PT - Pompa predisposta

MA - Motor
PA - Pump
PT - Adapted Pump

MA - Motor
PA - Pumpe
PT - Vorbereitete Pumpe

GRUPPO
GROUP
BAUGROSSE

1

CILINDRATA
DISPLACEMENT
FÖRDERVOLUMEN

14 - 1,37
19 - 1,90
24 - 2,53
31 - 3,17
36 - 3,73
44 - 4,35
48 - 4,97
60 - 6,08
70 - 7,00
80 - 7,87

SENSO DI ROTAZIONE
ROTATION
DREHRICHTUNG

S - Antioraria/sinistra
D - Oraria/destra
H - Bidirezionale drenaggio interno
B - Bidirezionale drenaggio esterno posteriore

S - Counterclockwise
D - Clockwise
H - Reversible ind. drain.
B - Reversible rear. drain. pont.

S - Linkslauf
D - Rechtslauf
H - reversibel, Lecköl intern, Anschluß seitlich
B - reversibel, Lecköl extern, Anschluß hinten

SET VALVOLE
VALVE SETTING
VENTILEINSTELLUNG
(bar)

COPERCHI - COVERS - DECKEL

ST - Standard
V. - Con valvole
(Vedi sez. valvole)
With valves
(See valves section)
Mit Ventilen
(siehe Abschnitt Ventile)

GUARNIZIONI - SEALS - DICHTUNGEN

B - NBR
R - NBR alte pres. (picco 25 bar)
For high pres. (peak 25 bar)
Hochdruck (spitzen 25 bar)

V - Viton
W - Viton alte pres. (picco 25 bar)
For high pres. (peak 25 bar)
Hochdruck (spitzen 25 bar)

BOCCHIE STD - STANDARD PORT - STANDARD ANSCHLÜSSE
CILINDRATA - DISPLACEMENT - FÖRDER-/SCHLUCKVOLUMEN

1,4.....4,8		6.....8		DRAIN		1,4.....4,8		6.....8		DRAIN	
Pompe - Pumps	Pompe - Pumps	Pompe - Pumps	Pompe - Pumps	IN/OUT	IN/OUT	Pompe - Pumps	Pompe - Pumps	Pompe - Pumps	Pompe - Pumps	IN/OUT	IN/OUT
*E2 E2	*E3 E3	M1	M1	U3 U3	U4 U4	U2	U2	U3 U3	U4 U4	U2	U2
G3 G3	G4 G4	G2	G2	T3 H1	T3 H1	-	-	T3 T3	T4 T3	G2	G2
X3 X3	X3 X3	M1	M1	C3 C3	C4 C3	U2	U2				
M4 M2	M4 M2	M1	M1								

MOTORI - MOTORS - MOTOREN OUT/IN
MOTORI BIDIR. IN=OUT - REVERS. MOTORS IN=OUT -
BIDIREK. MOTOREN IN=OUT

ESTREMITÀ D'ALBERO
SHAFT PROFIL
WELLENENDE

D - Conico (1:8)
E - Cilindrico europeo
F - Cilindrico SAE "AA"
G - Conico (1:5)
H - Scanalato 12x9
I - Scanalato SAE "AA"
J - Dente frontale sporgente
K - Dente frontale
T - Conico high torque (1:8)

D - Tapered (1:8)
E - European parallel shaft
F - SAE "AA" parallel shaft
G - Tapered (1:5)
H - Splined 12x9
I - SAE "AA" splined
J - Front tooth
K - Tang drive
T - Tapered high torque (1:8)

D - Kegel (1:8)
E - zylindrisch (E-norm)
F - zylindrisch SAE "AA"
G - Kegel (1:5)
H - Keilwelle 12x9
I - Keilwelle SAE "AA"
J - Vorstehendes Kreuzprofil
K - Kreuzprofil
T - verstärkter Kegel (1:8)

FLANGIA ANTERIORE
FRONT FLANGE
VORDERER FLANSCH

D - Europea D 25,4
E - Europea D 30
G - Tedesca con OR
J - SAE AA

D - European standard
E - European Ø 30
G - German wih OR
J - SAE AA

D - EU-Norm.D 25,4
E - EU-Norm.D 30
G - DIN-Norm.(mit O.R. Dichtung)
J - SAE AA

* Non disponibile con flangia G

* Not available with G flange

* Nicht mit Flansch G erhältlich

HPL ..2

POMPE E MOTORI AD INGRANAGGI GEAR PUMPS AND MOTORS ZAHNRADPUMPEN UND -MOTOREN

HPL PA2

POMPE AD INGRANAGGI GEAR PUMPS ZAHNRADPUMPEN

DATI TECNICI TECHNICAL DATA TECHNISCHE MERKMALE



DIAGRAMMA PORTATE DIAGRAMS KENNLINIEN

GRUPPO GROUP BAUREIHE	TIPO TYPE TYP	CILINDRATA TEORICA NOMINAL DISPLACEMENT FORDERVOLUMEN (TM)		PRESSIONE PRESSURE DRUCK INTERMITTENTE INTERMITTIERENDER				VELOCITÀ DI ROTAZIONE SPEED DREHZAHL		MASSA WEIGHT GEWICHT			
		cm ³	in ³	CONTINUA CONTINUOS DAUER		PICCO PEAK SPITZEN		MAX	MIN	kg	lbs		
				bar	psi	bar	psi						
2	05	4,50	0,27	240	3481	260	3771	300	4351	3500	700	2,30	5,07
	06	6,00	0,37	240	3481	260	3771	300	4351			2,40	5,29
	08	8,50	0,52	230	3336	250	3626	280	4061			2,40	5,29
	11	11,00	0,67	230	3336	250	3626	280	4061			2,40	5,29
	14	14,50	0,88	230	3336	250	3626	280	4061			2,80	6,17
	17	17,00	1,04	230	3336	250	3626	280	4061			2,80	6,17
	20	19,50	1,19	200	2901	220	3191	250	3626			2,80	6,17
	26	26,00	1,59	180	2611	190	2756	210	3046			3,10	6,83
	34	34,00	2,07	150	2175	170	2466	190	2756			3,40	7,50
	40	40,50	2,47	140	2031	160	2321	180	2611			3,60	7,94

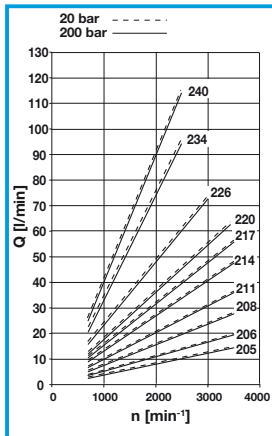

HPL MA2

MOTORI AD INGRANAGGI GEAR MOTORS ZAHNRADMOTOREN

DATI TECNICI TECHNICAL DATA TECHNISCHE MERKMALE



DIAGRAMMA PORTATE DIAGRAMS KENNLINIEN

GRUPPO GROUP BAUREIHE	TIPO TYPE TYP	CILINDRATA TEORICA NOMINAL DISPLACEMENT FORDERVOLUMEN (TM)		PRESSIONE PRESSURE DRUCK INTERMITTENTE INTERMITTIERENDER				VELOCITÀ DI ROTAZIONE SPEED DREHZAHL		MASSA WEIGHT GEWICHT			
		cm ³	in ³	CONTINUA CONTINUOS DAUER		PICCO PEAK SPITZEN		MAX	MIN	kg	lbs		
				bar	psi	bar	psi						
2	06	6,00	0,37	240	3481	260	3771	300	4351	4000	700	2,40	5,29
	08	8,50	0,52	230	3336	250	3626	280	4061			2,40	5,29
	11	11,00	0,67	230	3336	250	3626	280	4061			2,40	5,29
	14	14,50	0,88	230	3336	250	3626	280	4061			2,80	6,17
	17	17,00	1,04	230	3336	250	3626	280	4061			2,80	6,17
	20	19,50	1,19	200	2901	220	3191	250	3626			2,80	6,17
	26	26,00	1,59	180	2611	190	2756	210	3046			3,10	6,83

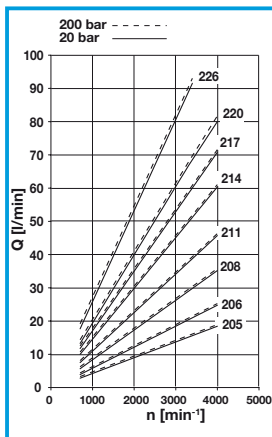

**DIMENSIONI
SIZE
ABMESSUNGEN**

HPL..2

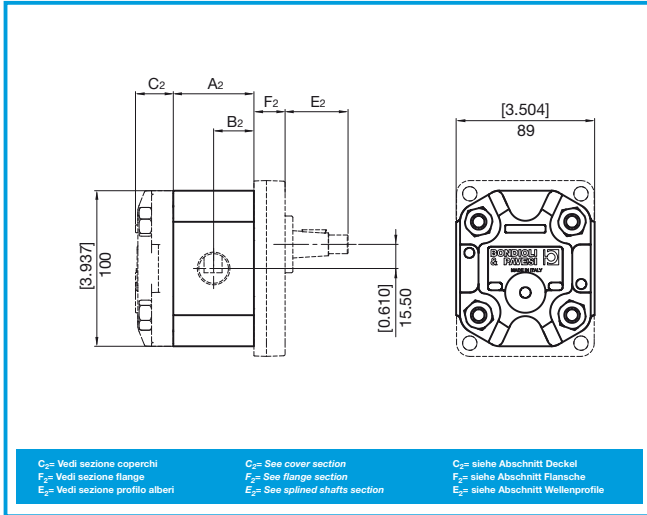

**DIMENSIONI
SIZE
ABMESSUNGEN**

GRUPPO GROUP BAUREIHE	TIPO TYPE TYP	A ₂		B ₂	
		mm	in	mm	in
2	05	49,15	1,935	24,6	0,968
	06	51,85	2,041	25,9	1,021
	08	56,35	2,219	28,2	1,109
	11	60,85	2,396	30,4	1,198
	14	67,25	2,648	33,6	1,324
	17	71,75	2,825	35,9	1,412
	20	76,25	3,002	38,1	1,501
	26	88,55	3,486	44,3	1,743
	34	102,55	4,037	51,3	2,019
	40	115,07	4,530	57,5	2,265

**COPERCHI
COVERS
DECKEL**

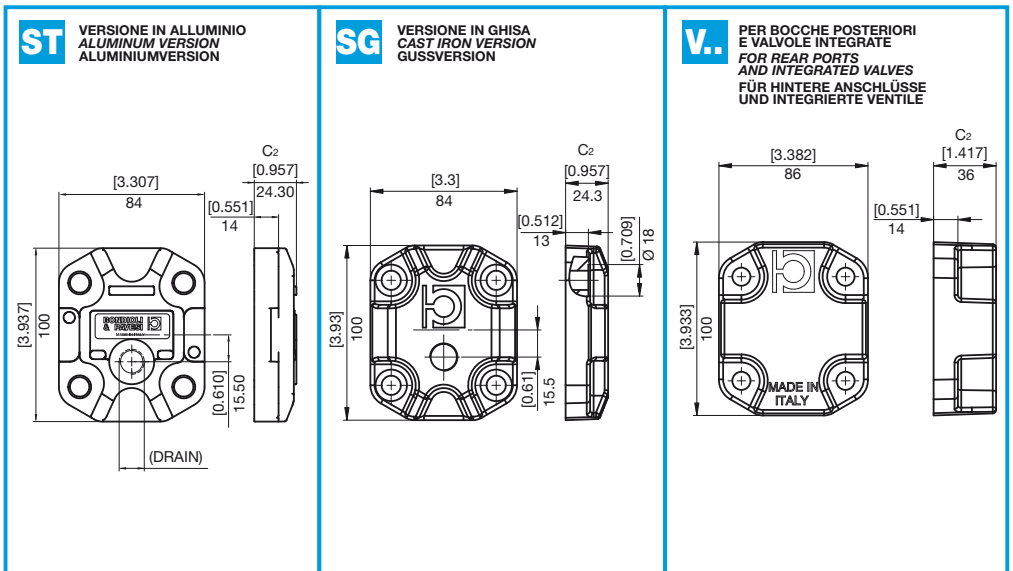

FLANGE
FLANGES
FLANSCHEN

VERSIONE IN ALLUMINIO
ALUMINUM VERSION
ALUMINIUMVERSION

HPL...2

M

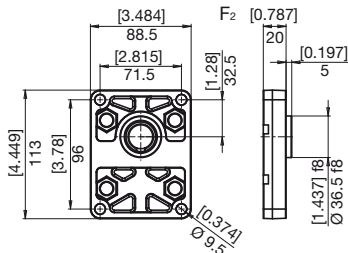

N

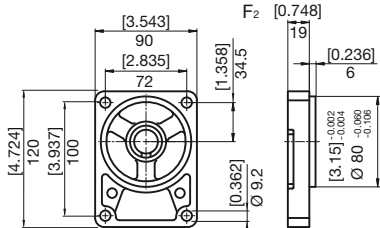

O

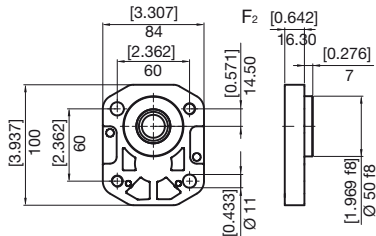

P

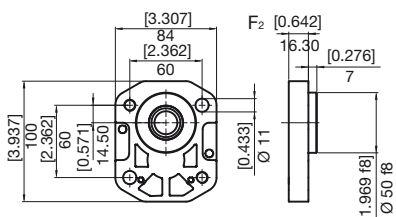

R

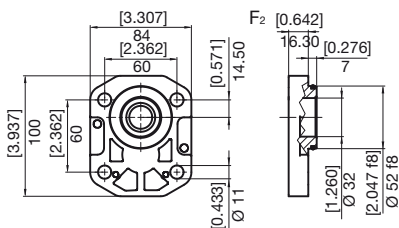

S

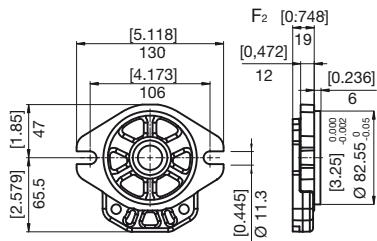



FLANGE
FLANGES
FLANSCH

VERSIONE IN GHISA
CAST IRON VERSION
GUSSVERSION

HPL..2

L

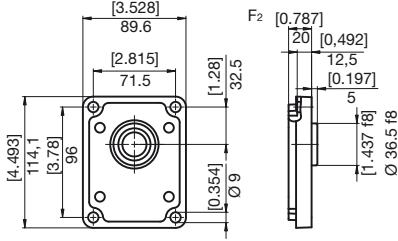

Q

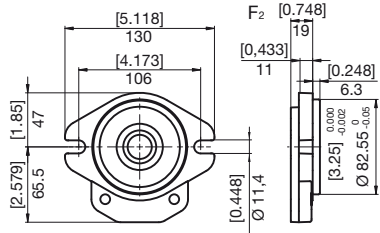

T

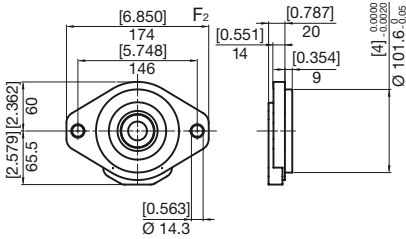

U

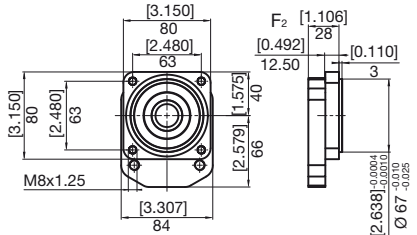

V

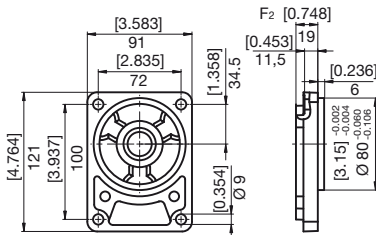

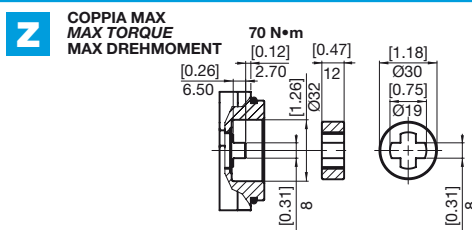
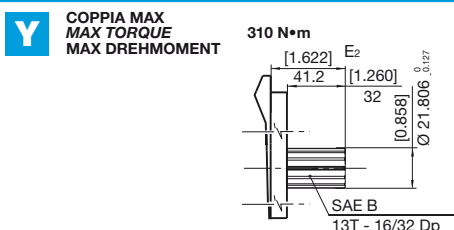
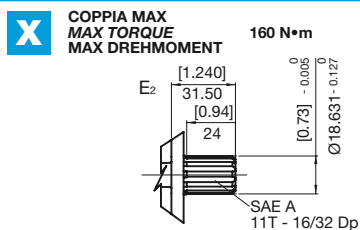
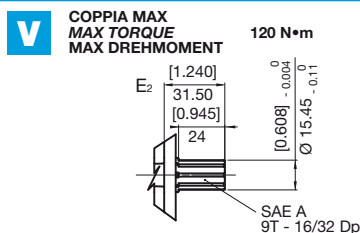
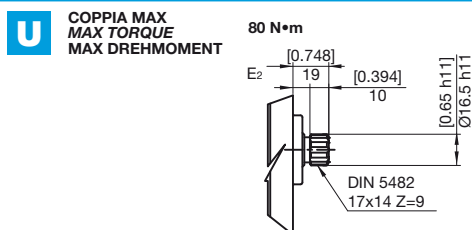
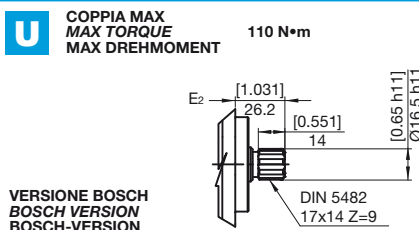
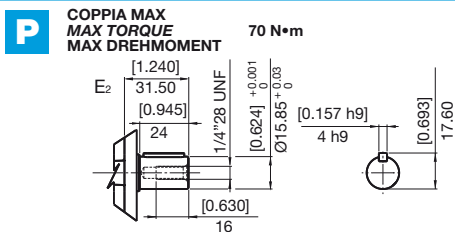
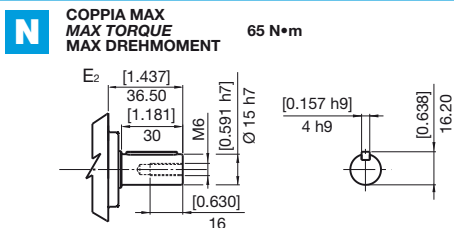
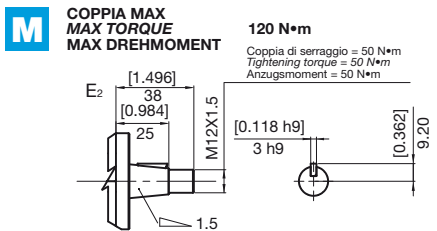
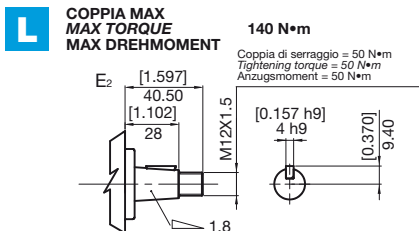



**BOCCHIE
PORTS
ANSCHLÜSSE**

HPL..2

E LATERALE
LATERAL
SEITLICH

TIPO TYPE TYP	M		N		O	
	mm	in	mm	in		Nm
E3	13	0,51	30	1,18	M6	10
E5	20	0,79	40	1,57	M8	15

X LATERALE
LATERAL
SEITLICH

TIPO TYPE TYP	M		N		O	
	mm	in	mm	in		Nm
X4	15	0,59	35	1,38	M6	10
X5	15	0,59	40	1,57	M6	10
X6	20	0,79	40	1,57	M6	10
X8	27	1,06	55	2,17	M8	15

G LATERALE
LATERAL
SEITLICH
T POSTERIORE
REAR
HINTEN

TIPO TYPE TYP	M		P	
		Nm	mm	in
*G3	3/8" GAS BSPP	38	12	0,47
G4	1/2" GAS BSPP	50	16	0,63
G6	3/4" GAS BSPP	90	19	0,75
G7	1" GAS BSPP	130	19	0,75
T4	1/2" GAS BSPP	50	14,5	0,63
T6	3/4" GAS BSPP	40	19	0,75

U LATERALE
LATERAL
SEITLICH
C POSTERIORE
REAR
HINTEN

TIPO TYPE TYP	DIMENSIONE SIZE GRÖSSE	N		P		Q		M	
		mm	in	mm	in	mm	in		Nm
*U3	3/8"	25	0,98	13	0,51	0,3	0,01	9/16-18 UNF	25
U5	5/8"	34	1,34	17	0,67	0,3	0,01	7/8-14 UNF	70
U6	3/4"	41	1,61	19	0,75	0,3	0,01	1-1/16-12 UNF	90
U7	1"	49	1,93	20	0,79	0,3	0,01	1-5/16-12 UNF	130
C5	5/8"	34	1,34	17	0,67	0,3	0,01	7/8-14 UNF	70
C6	3/4"	41	1,61	19	0,75	0,3	0,01	1-1/16-12 UNF	40

N LATERALE
LATERAL
SEITLICH

TIPO TYPE TYP	DIMENSIONE SIZE GRÖSSE	M		P		Q		O	
		mm	in	mm	in	mm	in		Nm
N4	1/2"	13	0,51	38,1	1,49	17,5	0,68	5/16-18UNC-2B	15
N6	3/4"	20	0,79	47,6	1,87	22,2	0,87	3/8"-16UNC-2B	25
N7	1"	27	1,06	52,4	2,60	26,2	1,03	3/8"-16UNC-2B	30













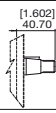



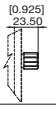
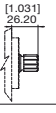

M

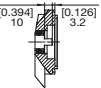
TIPO TYPE TYP	M		P	
		Nm	mm	in
*M2	M14x1,5	17	12	0,47

* Drenaggio

* Drain Port

* Lecköl

ESTREMITÀ ALBERO SHAFT PROFIL WELLE ENDE	FLANGE FLANGE FLANSCH							
	M L	N V	O P	R	S Q	T	U	
L 	<input checked="" type="checkbox"/>							
M 		<input checked="" type="checkbox"/>						
N 	<input checked="" type="checkbox"/>							
P 					<input checked="" type="checkbox"/>			
U 	<input checked="" type="checkbox"/>							
V 					<input checked="" type="checkbox"/>			
X 					<input checked="" type="checkbox"/>			
Y 						<input checked="" type="checkbox"/>		
Z 				<input checked="" type="checkbox"/>				
BOCCHE PORTS ANSCHLÜSSE								
E 	<input checked="" type="checkbox"/>							
G 	<input checked="" type="checkbox"/>				<input checked="" type="checkbox"/>	<input checked="" type="checkbox"/>	<input checked="" type="checkbox"/>	
X 		<input checked="" type="checkbox"/>	<input checked="" type="checkbox"/>	<input checked="" type="checkbox"/>				
U 					<input checked="" type="checkbox"/>	<input checked="" type="checkbox"/>		
N 					<input checked="" type="checkbox"/>	<input checked="" type="checkbox"/>		
C 					<input checked="" type="checkbox"/>	<input checked="" type="checkbox"/>		
T 	<input checked="" type="checkbox"/>	<input checked="" type="checkbox"/>	<input checked="" type="checkbox"/>	<input checked="" type="checkbox"/>	<input checked="" type="checkbox"/>	<input checked="" type="checkbox"/>	<input checked="" type="checkbox"/>	



ISTRUZIONI PER L'ORDINAZIONE
ORDERING INSTRUCTIONS
BESTELLANLEITUNG

HPL..2



SERIE
SERIES
SERIE

PRODOTTO
PRODUCT
PRODUKT

MA - Motore
PA - Pompa singola
PT - Pompa predisposta

MA - Motor
PA - Pump
PT - Adapted Pump

MA - Motor
PA - Pumpe
PT - Vorbereitete Pumpe

GRUPPO
GROUP
BAUGROSSE **2**

CILINDRATA
DISPLACEMENT
FÖRDERVOLUMEN

- 05 - 4,50
- 06 - 6,00
- 08 - 8,50
- 11 - 11,00
- 14 - 14,50
- 17 - 17,00
- 20 - 19,50
- 26 - 26,00
- 34 - 34,00
- 40 - 40,50

SENSO DI ROTAZIONE
ROTATION
DREHRICHTUNG

S - Antioraria/sinistra
D - Oraria/destra
H - Bidirezionale drenaggio interno
B - Bidirezionale drenaggio esterno posteriore

S - Counterclockwise
D - Clockwise
H - Reversible ind drain
B - Reversible rear. drain. pont

S - Linkslauf
D - Rechtslauf
H - reversibel, Lecköl intern, Anschluß seitlich
B - reversibel, Lecköl extern, Anschluß hinten

* Non disponibile per cilindrata 05
* Not available for displacement 05
* Nicht verfügbar für förderolumen 05

SET VALVOLE
VALVE SETTING
VENTILEINSTELLUNG
(bar)

COPERCHI - COVERS - DECKEL
ST - Standard
SG - Versione in ghisa
Cast iron version
Gussversion
V. - Con valvole (Vedi sez. valvole)
With valves (See valves section)
Mit Ventilen
(siehe Abschnitt Ventile)

GUARNIZIONI - SEALS - DICHTUNGEN
B - NBR
R - NBR alte pres. (picco 25 bar)
For high pres. (peak 25 bar)
Hochdruck (spitzen 25 bar)
V - Viton
W - Viton alte pres. (picco 25 bar)
For high pres. (peak 25 bar)
Hochdruck (spitzen 25 bar)

BOCCHIE STD - STANDARD PORT - STANDARD ANSCHLÜSSE
CILINDRATA - DISPLACEMENT - FÖRDER-/SCHLUCKVOLUMEN

5.....8		11	14.....20		26	34.....40	DRAIN
Pompe - Pumps - Pumpen	IN/OUT	Pompe - Pumps - Pumpen	IN/OUT	Pompe - Pumps - Pumpen	IN/OUT	Pompe - Pumps - Pumpen	IN/OUT
E3 E3		E5 E3		E5 E5		E5 E5	M2
G4 G4		G6 G4		G6 G6		G7 G6	G3
X5 X4	X6 X4	X6 X4		X6 X5		X8 X6	M2
U6 U5		U6 U5		U6 U5		U7 U6	U3
N4 N4*		N6 N4		N7 N6		N7 N6	U3
C6 C5		C6 C5		C6 C5		C6 C5	U3
T6 T4		T6 T4		T6 T4		T6 T4	G3

MOTORI - MOTORS - MOTOREN OUT/IN
MOTORI BIDIR. IN=OUT - REVERS. MOTORS IN=OUT -
BIDIREK.MOTOREN IN=OUT

FLANGIA ANTERIORE
FRONT FLANGE
VORDERER FLANSCH
L - Europea in ghisa
M - Europea
N - Tedesca
O - Tedesca D 50 2 fori DX
P - Tedesca D 50 2 fori SX
Q - Tedesca D 52
R - SAE A 2 fori
S - SAE A 2 fori
T - SAE B 2 fori in ghisa
U - Perkins
V - Tedesca in ghisa
L - European cast iron
M - European
N - German
O - German D 50 2 holes right
P - German D 50 2 holes left
Q - SAE A 2 holes cast iron
R - German D 52
S - SAE A 2 holes
T - SAE B 2 holes cast iron
U - Perkins
V - German cast iron
L - EU-Norm G10
M - EU-Norm
N - DIN-Norm
O - DIN-Norm D 50 Bohrungen rechts
P - DIN-Norm D 50 Bohrungen links
Q - SAE A 2 Bohrungen Guß
R - DIN-Norm D 52
S - SAE A 2 Bohrungen
T - SAE B 2 Bohrungen Guß
U - Perkins
V - Din gussversion

ESTREMITÀ D'ALBERO
SHAFT PROFIL
WELLENENDE
L - Conico (1:8)
M - Conico (1:5)
N - Cilindrico D15 europeo
P - Cilindrico SAE "A"
U - Scanalato DIN 5482
V - Scanalato SAE "A" 9T
X - Scanalato SAE "A" 11T
Y - Scanalato SAE "B" 13T
Z - Dente frontale
L - Tapered (1:8)
M - Tapered (1:5)
N - D15 European parallel shaft
P - SAE "A" parallel shaft
U - DIN 5482 splined
V - SAE "A" 9T splined
X - SAE "A" 11T splined
Y - SAE "B" 13T splined
Z - Tang drive
L - Kegel (1:8)
M - Kegel (1:5)
N - zylindrisch D15 (E-norm)
P - zylindrisch SAE "A"
U - Keilwelle DIN 5482
V - Keilwelle SAE "A" 9T
X - Keilwelle SAE "A" 11T
Y - Keilwelle SAE "B" 13T
Z - Kreuzprofil

HPL ..3

POMPE E MOTORI AD INGRANAGGI GEAR PUMPS AND MOTORS ZAHNRADPUMPEN UND -MOTOREN

HPL PA3

POMPE AD INGRANAGGI
GEAR PUMPS
ZAHNRADPUMPEN

DATI TECNICI TECHNICAL DATA TECHNISCHE MERKMALE



GRUPPO GROUP BAUREIHE	TIPO TYPE	CILINDRATA TEORICA NOMINAL DISPLACEMENT FÖRDEVOLUMEN (TM)		CONTINUA CONTINUOUS DAUER		PRESSIONE PRESSURE DRUCK INTERMITTENTE INTERMITTENT INTERMITTIERENDER		PICCO PEAK SPITZEN		VELOCITÀ DI ROTAZIONE SPEED DREHZAHL		MASSA WEIGHT GEWICHT	
		cm ³	in ³	bar	psi	bar	psi	bar	psi	MAX	MIN	kg	lbs
3	22	21,50	1,31	220	3191	250	3626	310	4496	3000	700	6,20	13,67
	26	26,00	1,59	210	3046	250	3626	300	4351			6,20	13,67
	31	30,50	1,86	210	3046	250	3626	280	4061			6,20	13,67
	36	36,00	2,20	210	3046	250	3626	280	4061			6,50	14,33
	41	41,50	2,53	210	3046	250	3626	280	4061			7,20	15,87
	47	46,50	2,84	180	2611	210	3046	270	3916	7,20	15,87		
	51	50,50	3,08	180	2611	210	3046	270	3916	7,20	15,87		
	56	55,50	3,39	170	2466	200	2901	230	3336	7,40	16,31		
	61	61,00	3,72	150	2176	180	2611	200	2901	7,60	16,76		
	73	72,00	4,39	140	2031	150	2176	180	2611	8,00	17,64		
90	88,00	5,37	110	1595	120	1740	170	2466	8,60	18,96			

DIAGRAMMA PORTATE DIAGRAMS KENNLINIEN

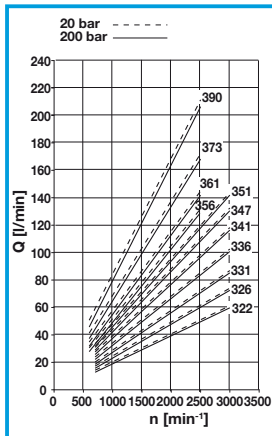

HPL MA3

MOTORI AD INGRANAGGI
GEAR MOTORS
ZAHNRADMOTOREN

DATI TECNICI TECHNICAL DATA TECHNISCHE MERKMALE



GRUPPO GROUP BAUREIHE	TIPO TYPE	CILINDRATA TEORICA NOMINAL DISPLACEMENT FÖRDEVOLUMEN (TM)		CONTINUA CONTINUOUS DAUER		PRESSIONE PRESSURE DRUCK INTERMITTENTE INTERMITTENT INTERMITTIERENDER		PICCO PEAK SPITZEN		VELOCITÀ DI ROTAZIONE SPEED DREHZAHL		MASSA WEIGHT GEWICHT	
		cm ³	in ³	bar	psi	bar	psi	bar	psi	MAX	MIN	kg	lbs
3	22	21,50	1,31	220	3191	250	3626	310	4496	3500	700	6,20	13,67
	26	26,00	1,59	210	3046	250	3626	300	4351			6,20	13,67
	31	30,50	1,86	210	3046	250	3626	280	4061			6,20	13,67
	36	36,00	2,20	210	3046	250	3626	280	4061			6,50	14,33
	41	41,50	2,53	210	3046	250	3626	280	4061			7,20	15,87
	47	46,50	2,84	180	2611	210	3046	270	3916	7,20	15,87		
	51	50,50	3,08	180	2611	210	3046	270	3916	7,20	15,87		
	56	55,50	3,39	170	2466	200	2901	230	3336	7,40	16,31		
	61	61,00	3,72	150	2176	180	2611	200	2901	7,60	16,76		
	73	72,00	4,39	140	2031	150	2176	180	2611	8,00	17,64		

DIAGRAMMA PORTATE DIAGRAMS KENNLINIEN

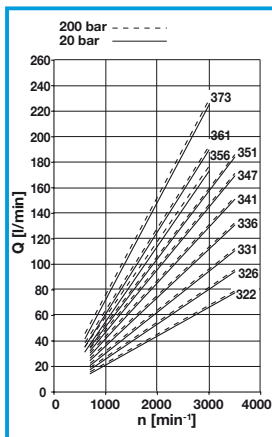



**DIMENSIONI
SIZE
ABMESSUNGEN**

HPL..3

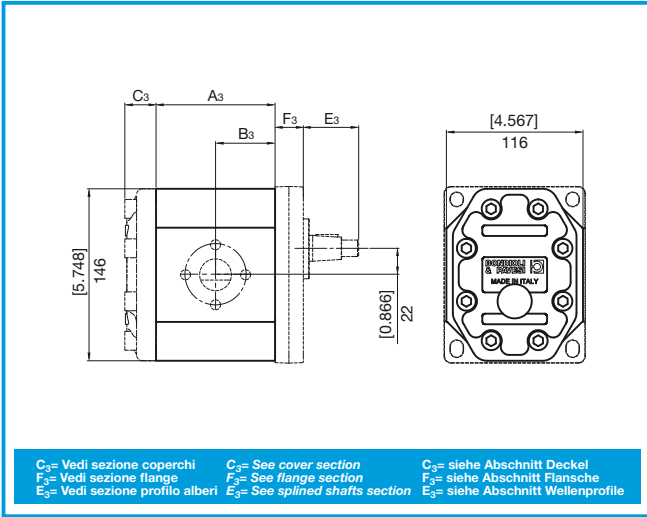

**DIAGRAMMA PORTATE
DIAGRAMS
KENNLINIEN**

GRUPPO GROUP BAUREIHE	TIPO TYPE TYP	A ₃		B ₃	
		mm	in	mm	in
3	22	81,07	3,192	40,5	1,594
	26	84,07	3,310	42,0	1,654
	31	87,07	3,428	43,5	1,714
	36	91,07	3,585	45,5	1,793
	41	95,07	3,743	47,5	1,870
	47	98,07	3,861	49,0	1,929
	51	101,07	3,979	50,5	1,990
	56	104,57	4,117	52,3	2,059
	61	108,57	4,274	54,3	2,137
	73	116,07	4,570	58,0	2,285
90	127,07	5,003	63,5	2,501	

**COPERCHI
COVERS
DECKEL**

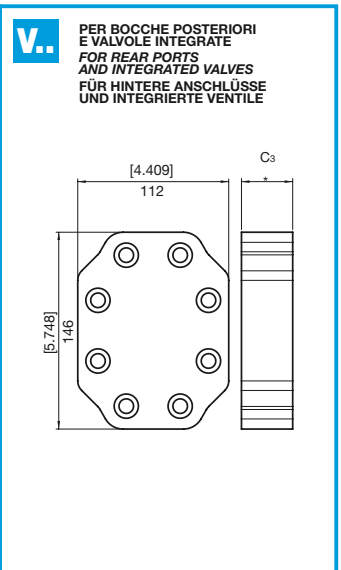
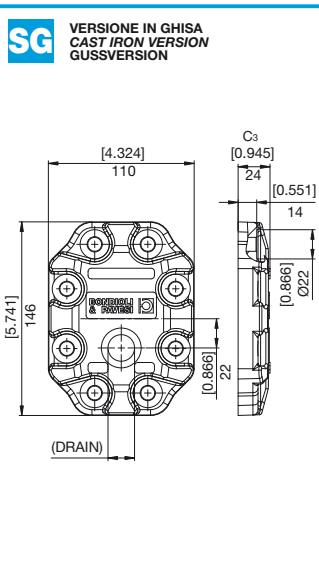
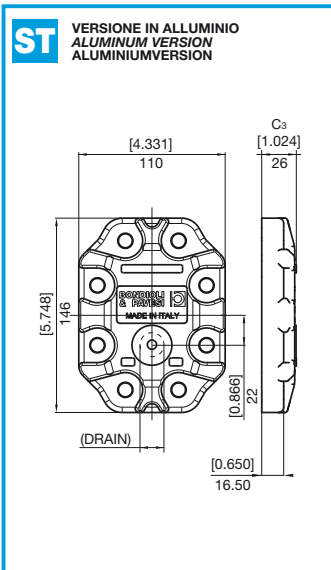

FLANGE
FLANGES
FLANSCH

VERSIONE IN ALLUMINIO
ALUMINUM VERSION
ALUMINIUMVERSION

VERSIONE IN GHISA
CAST IRON VERSION
GUSSVERSION

HPL...3

W

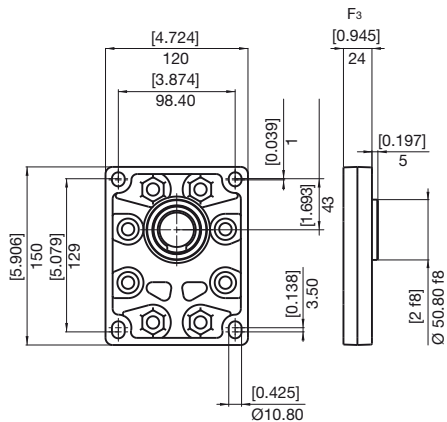

Y

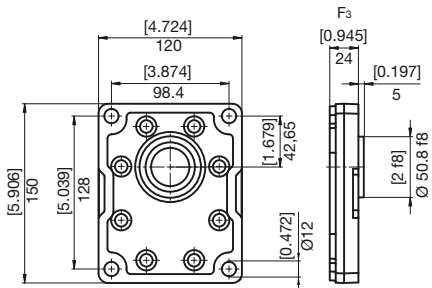

Z

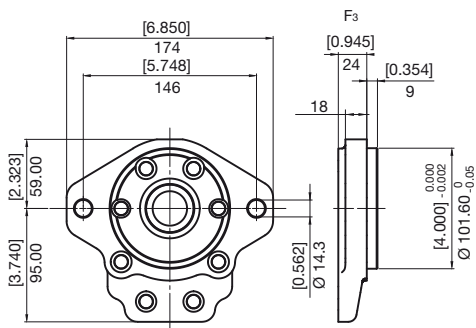

F

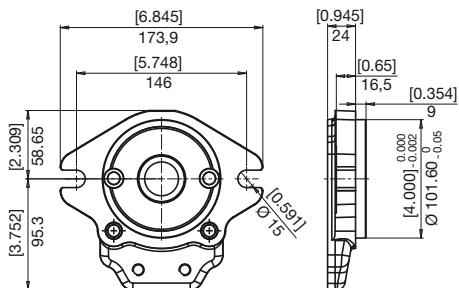



**PROFILO ALBERI
SPLINE SHAFTS
WELLENPROFILE**

HPL..3

1

**COPPIA MAX
MAX TORQUE
MAX DREHMOMENT**

460 N•m

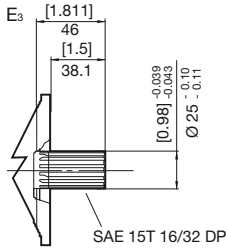

2

**COPPIA MAX
MAX TORQUE
MAX DREHMOMENT**

240 N•m

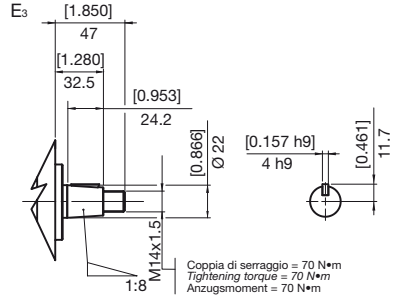

4

**COPPIA MAX
MAX TORQUE
MAX DREHMOMENT**

190 N•m

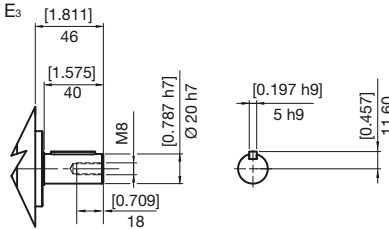

6

**COPPIA MAX
MAX TORQUE
MAX DREHMOMENT**

210 N•m

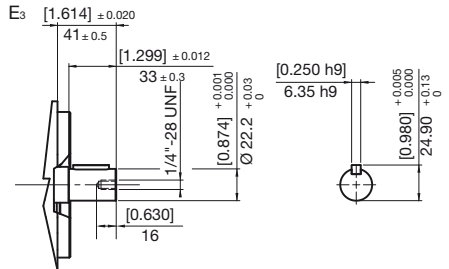

7

**COPPIA MAX
MAX TORQUE
MAX DREHMOMENT**

220 N•m

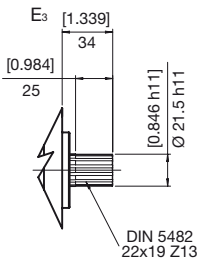

9

**COPPIA MAX
MAX TORQUE
MAX DREHMOMENT**

310 N•m

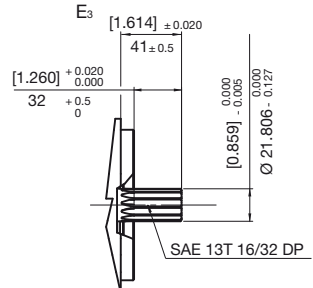

**BOCCH
PORTS
ANSCHLÜSSE**

HPL...3

E LATERALE
LATERAL
SEITLICH



TIPO TYPE TYP	M		N		O	
	mm	in	mm	in		Nm
E5	20	0,79	40	1,57	M8	15
E7	27	1,06	51	2,01	M10	30
E8	34	1,34	62	2,44	M10	30

G LATERALE
LATERAL
SEITLICH

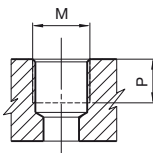

TIPO TYPE TYP	M		P	
	Nm	mm	in	
*G3	3/8" GAS BSPP	38	12	0,47
G6	3/4" GAS BSPP	90	20	0,78
G7	1" GAS BSPP	130	21	0,83
G8	1 1/4" GAS BSPP	70	21	0,83

U LATERALE
LATERAL
SEITLICH

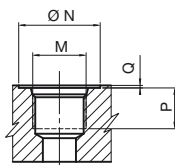

TIPO TYPE TYP	DIMENSIONE SIZE GRÖSSE	N		P		Q		M	
		mm	in	mm	in	mm	in		Nm
U6	3/4"	41	1,61	20	0,79	0,3	0,01	1-1/16"-12 UNF	90
U7	1"	49	1,93	20	0,79	0,3	0,01	1-5/16"-12UNF	130
U8	1 1/4"	58	2,28	20	0,79	0,3	0,01	1-5/8"-12 UNF	70

N LATERALE
LATERAL
SEITLICH

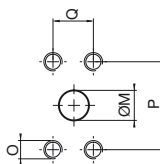

TIPO TYPE TYP	DIMENSIONE SIZE GRÖSSE	M		P		Q		O	
		mm	in	mm	in	mm	in		Nm
N6	3/4"	20	0,79	47,6	1,87	22,2	0,87	3/8"-16UNC-2B	25
N7	1"	27	1,06	52,4	2,60	26,2	1,03	3/8"-16UNC-2B	30
N8	1 1/4"	34	1,34	58,7	2,31	30,2	1,19	7/16"-14UNC-2B	45

X LATERALE
LATERAL
SEITLICH

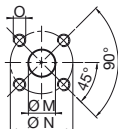

TIPO TYPE TYP	M		N		O	
	mm	in	mm	in		Nm
X7	19	0,75	55	2,17	M8	15
X8	27	1,06	55	2,17	M8	15

M

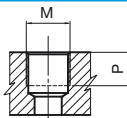

TIPO TYPE TYP	M		P	
	Nm	mm	in	
*M3	M16x1,5	35	12	0,47

* Drenaggio

* Drain Port

* Lecköl



**COMBINAZIONI
COMBINATIONS
KOMBINATIONEN**

HPL..3

ESTREMITÀ ALBERO SHAFT PROFIL WELLENEUDE	FLANGE FLANGE FLANSCH	
	W Y	Z F
1		
2		
4		
6		
7		
9		
BOCCHE PORTS ANSCHLÜSSE		
E		
G		
U		
N		
X		

Questa pagina è intenzionalmente bianca
This page is intentionally blank
Diese Seite ist bewusst frei gelassen



ISTRUZIONI PER L'ORDINAZIONE
ORDERING INSTRUCTIONS
BESTELLANLEITUNG

HPL..3



SERIE
SERIES
SERIE

PRODOTTO
PRODUCT
PRODUKT

MA - Motore
PA - Pompa singola
PT - Pompa predisposta

MA - Motor
PA - Pump
PT - Adapted Pump

MA - Motor
PA - Pumpe
PT - Vorbereitete Pumpe

GRUPPO
GROUP
BAUGRÖSSE

3

CILINDRATA
DISPLACEMENT
FÖRDERVOLUMEN

- 22 - 21,50
- 26 - 26,00
- 31 - 30,50
- 36 - 36,00
- 41 - 41,50
- 47 - 46,50
- 51 - 50,50
- 56 - 55,50
- 61 - 61,00
- 73 - 72,00
- 90 - 88,00

SENSO DI ROTAZIONE
ROTATION
DREHRICHTUNG

S - Antioraria/sinistra
D - Oraria/destra
H - Bidirezionale drenaggio interno
B - Bidirezionale drenaggio esterno posteriore

S - Counterclockwise
D - Clockwise
H - Reversible ind. drain.
B - Reversible rear. drain. pont.

S - Linkslauf
D - Rechtslauf
H - reversibel, Lecköl intern, Anschluß seitlich
B - reversibel, Lecköl extern, Anschluß hinten

SET VALVOLE
VALVE SETTING
VENTILEINSTELLUNG
(bar)

COPERCHI - COVERS - DECKEL

ST - Standard
SG - Versione in ghisa
cast iron version
Gussversion
V.. - Con valvole
(Vedi sez. valvole)
With valves
(See valves section)
Mit Ventilen
(siehe Abschnitt Ventile)

GUARNIZIONI
SEALS
DICHTUNGEN

B - NBR
R - NBR alte pres. (picco 25 bar)
For high pres. (peak 25 bar)
Hochdruck (spitzen 25 bar)
V - Viton
W - Viton alte pres. (picco 25 bar)
For high pres. (peak 25 bar)
Hochdruck (spitzen 25 bar)

BOCCHIE STD - STANDARD PORT - STANDARD ANSCHLÜSSE
CILINDRATA - DISPLACEMENT - FÖRDER-SCHLUCKVOLUMEN

22.....31	36.....61	73.....90	DRAIN
Pompe - Pumps - Pumpen IN/OUT	Pompe - Pumps - Pumpen IN/OUT	Pompe - Pumps - Pumpen IN/OUT	
E5 E5	E7 E5	E8 E7	M3
G6 G6	G7 G6	G8 G7	G3
U7 U6	U8 U7	U8 U7	M3
N7 N6	N7 N6	N8 N7	M3
X8 X7	X8 X7	X8 X7	M3

MOTORI - MOTORS - MOTOREN OUT/IN
MOTORI BIDIR. IN=OUT - REVERS. MOTORS IN=OUT -
BIDIREK. MOTOREN IN=OUT

FLANGIA ANTERIORE
FRONT FLANGE
VORDERER FLANSCH

W - Europea D 50,8
Z - SAE B 2 fori
Y - Europea D 50,8 ghisa
F - SAE B 2 fori ghisa
W - European D 50,8
Z - SAE B 2 holes
Y - European D 50,8 cast iron
F - SAE B 2 holes cast iron
W - EU-Norm D 50,8
Z - SAE B 2 Bohrungen
Y - EU-Norm D 50,8 Guß
F - SAE B 2 Bohrungen Guß

ESTREMITÀ D'ALBERO
SHAFT PROFIL
WELLENENDE

- 1 - Scanalato SAE "BB" 15T
- 2 - Conico (1:8)
- 4 - Cilindrico europeo
- 6 - Cilindrico SAE "B"
- 7 - Scanalato DIN 5482
- 9 - Scanalato SAE "B" 13T
- 1 - SAE "BB" 15T splined
- 2 - Tapered (1:8)
- 4 - European parallel shaft
- 6 - SAE "B" parallel shaft
- 7 - DIN 5482 splined
- 9 - SAE "B" 13T splined
- 1 - Keilwelle SAE "BB" 15T
- 2 - Kegel (1:8)
- 4 - Kegel EU-Norm
- 6 - zylindrisch SAE "B"
- 7 - Keilwelle DIN 5482
- 9 - Keilwelle SAE "B" 13T

HPL ..4

POMPE E MOTORI AD INGRANAGGI GEAR PUMPS AND MOTORS ZAHNRADPUMPEN UND -MOTOREN

HPL PA4

POMPE AD INGRANAGGI
GEAR PUMPS
ZAHNRADPUMPEN

DATI TECNICI TECHNICAL DATA TECHNISCHE MERKMALE



DIAGRAMMA PORTATE DIAGRAMS KENNLIENEN

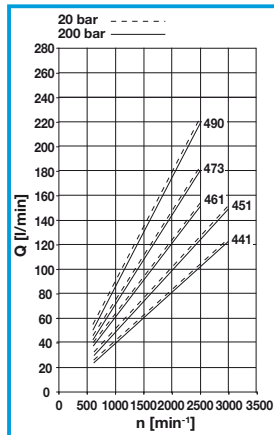

GRUPPO GROUP BAUREIHE	TIPO TYPE TYP	CILINDRATA TEORICA NOMINAL DISPLACEMENT FÖRDERVOLUMEN (TM)		CONTINUA CONTINUOUS DAUER		PRESSIONE PRESSURE DRUCK INTERMITTENTE INTERMITTENT INTERMITTIERENDER		PICCO PEAK SPITZEN		VELOCITÀ DI ROTAZIONE SPEED DREHZAHL		MASSA WEIGHT GEWICHT	
		cm ³	in ³	bar	psi	bar	psi	bar	psi	MAX	MIN	kg	lbs
4	41	41,50	2,53	220	3191	250	3626	300	4351	3000	700	9,20	20,28
	51	50,50	3,08	190	2756	210	3046	280	4061			9,20	20,28
	61	61,00	3,72	160	2321	180	2611	200	2901	2500	600	9,60	21,16
	73	72,00	4,39	150	2176	160	2321	180	2611			9,60	21,16
90	88,00	5,37	120	1740	130	1885	170	2466			9,60	21,16	

HPL MA4

MOTORI AD INGRANAGGI
GEAR MOTORS
ZAHNRADMOTOREN

DATI TECNICI TECHNICAL DATA TECHNISCHE MERKMALE



DIAGRAMMA PORTATE DIAGRAMS KENNLIENEN

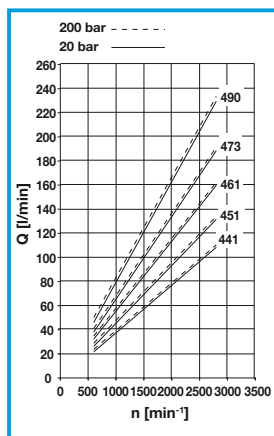

GRUPPO GROUP BAUREIHE	TIPO TYPE TYP	CILINDRATA TEORICA NOMINAL DISPLACEMENT FÖRDERVOLUMEN (TM)		CONTINUA CONTINUOUS DAUER		PRESSIONE PRESSURE DRUCK INTERMITTENTE INTERMITTENT INTERMITTIERENDER		PICCO PEAK SPITZEN		VELOCITÀ DI ROTAZIONE SPEED DREHZAHL		MASSA WEIGHT GEWICHT	
		cm ³	in ³	bar	psi	bar	psi	bar	psi	MAX	MIN	kg	lbs
4	41	41,50	2,53	220	3191	250	3626	300	4351	2800	600	9,20	20,28
	51	50,50	3,08	190	2756	210	3046	280	4061			9,20	20,28
	61	61,00	3,72	160	2321	180	2611	200	2901	2800	600	9,60	21,16
	73	72,00	4,39	150	2176	160	2321	180	2611			9,60	21,16
90	88,00	5,37	120	1740	130	1885	170	2466			9,60	21,16	



**DIMENSIONI
SIZE
ABMESSUNGEN**

HPL..4

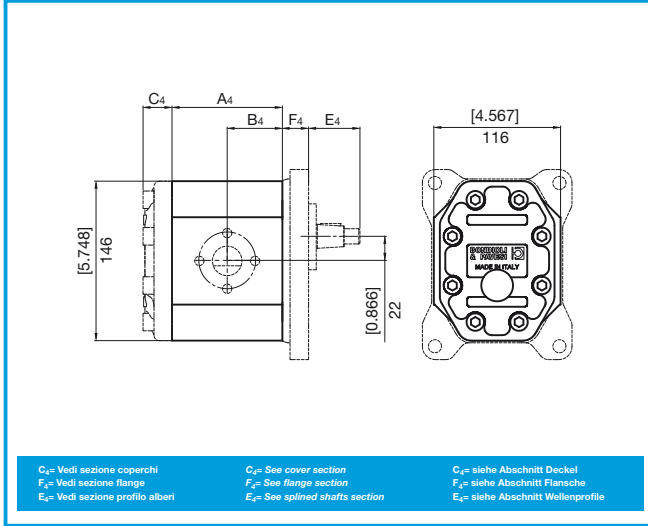

**DIMENSIONI
SIZE
ABMESSUNGEN**

GRUPPO GROUP BAUREIHE	TIPO TYPE TYP	A₄		B₄	
		mm	in	mm	in
4	41	101,07	3,979	50,5	1,990
	51	101,07	3,979	50,5	1,990
	61	108,57	4,274	54,3	2,137
	73	116,07	4,570	58,0	2,285
	90	127,07	5,003	63,5	2,501

**COPERCHI
COVERS
DECKEL**

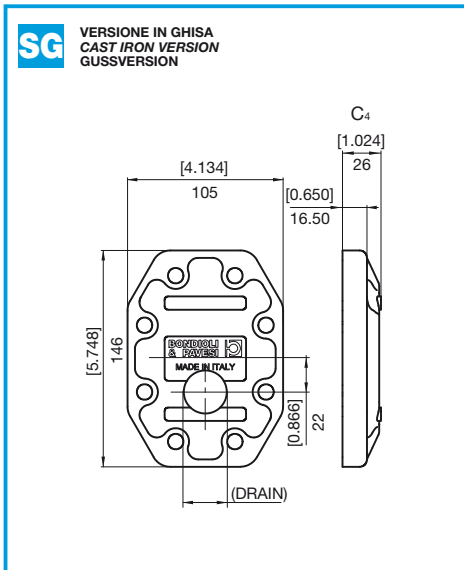

**FLANGE
FLANGES
FLANSCH**

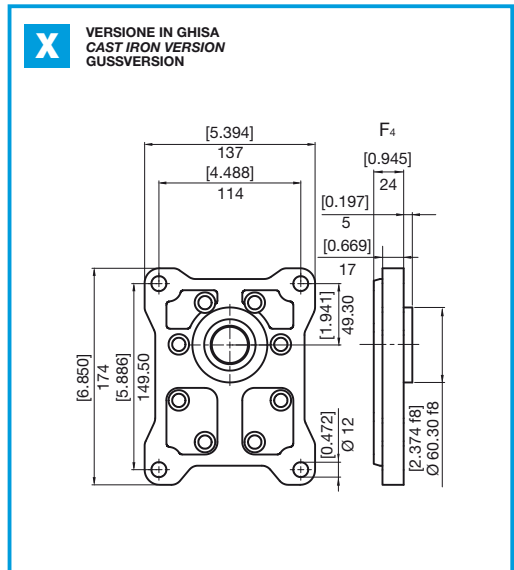

3 COPPIA MAX
MAX TORQUE
MAX DREHMOMENT 350 N•m

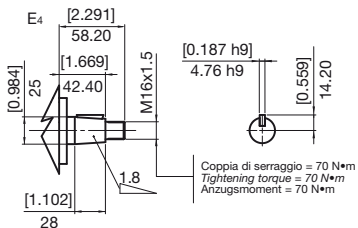

5 COPPIA MAX
MAX TORQUE
MAX DREHMOMENT 210 N•m

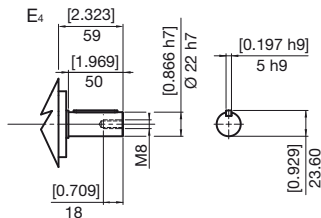

8 COPPIA MAX
MAX TORQUE
MAX DREHMOMENT 350 N•m

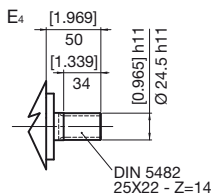

BOCCHE
PORTS
ANSCHLÜSSE

E LATERALE
LATERAL
SEITLICH

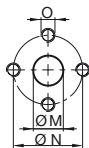

TIPO TYPE TYP	M		N		O	
	mm	in	mm	in		Nm
E7	27	1,06	51	2,01	M10	30
E8	34	1,34	62	2,44	M10	30

G LATERALE
LATERAL
SEITLICH

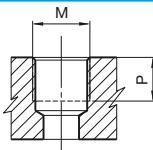

TIPO TYPE TYP	M		P	
	Nm	mm	in	
*G3	38	12	0,47	
G7	130	21	0,83	
G8	170	21	0,83	

X LATERALE
LATERAL
SEITLICH

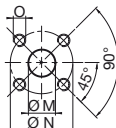

TIPO TYPE TYP	M		N		O	
	mm	in	mm	in		Nm
X7	19	0,75	55	2,17	M8	15
X8	27	1,06	55	2,17	M8	15

* Drenaggio













* Drain Port

* Lecköl



**COMBINAZIONI
COMBINATIONS
KOMBINATIONEN**

HPL..4

ESTREMITÀ ALBERO SHAFT PROFIL WELLENENDE		FLANGE FLANGE FLANSCHEN X 
3 		
5 		
8 		
BOCCHIE PORTS ANSCHLÜSSE		
E 		
G 		
X 		

Questa pagina è intenzionalmente bianca
This page is intentionally blank
Diese Seite ist bewusst frei gelassen



ISTRUZIONI PER L'ORDINAZIONE
ORDERING INSTRUCTIONS
BESTELLANLEITUNG

HPL..4

HPL PA 4 61 D X 3 E7 E7 B SG

SERIE
SERIES
SERIE

PRODOTTO
PRODUCT
PRODUKT

MA - Motore
PA - Pompa singola
PT - Pompa predisposta

MA - Motor
PA - Pump
PT - Adapted Pump

MA - Motor
PA - Pumpe
PT - Vorbereitete Pumpe

GRUPPO
GROUP
BAUGRÖSSE

4

CILINDRATA
DISPLACEMENT
FÖRDERVOLUMEN

41 - 41,50
51 - 50,50
61 - 61,00
73 - 72,00
90 - 88,00

SENSO DI ROTAZIONE
ROTATION
DREHRICHTUNG

S - Antioraria/sinistra
D - Oraria/destra
H - Bidirezionale drenaggio interno
B - Bidirezionale drenaggio esterno posteriore

S - Counterclockwise
D - Clockwise
H - Reversible ind drain.
B - Reversible rear. drain. pont.

S - Linkslauf
D - Rechtslauf
H - reversibel, Lecköl intern, Anschluß seitlich
B - reversibel, Lecköl extern, Anschluß hinten

COPERCHI
COVERS
DECKEL

SG - Versione in ghisa
Cast iron version
Gussversion

GUARNIZIONI
SEALS
DICHTUNGEN

B - NBR
R - NBR alte pres. (picco 25 bar)
For high pres. (peak 25 bar)
Hochdruck (spitzen 25 bar)
V - Viton
W - Viton alte pres. (picco 25 bar)
For high pres. (peak 25 bar)
Hochdruck (spitzen 25 bar)

BOCCHIE STD
STANDARD PORT
STANDARD ANSCHLÜSSE

CILINDRATA - DISPLACEMENT - FÖRDER-/SCHLUCKVOLUMEN

41.....61		73.....90		DRAIN
Pompe - Pumps - Pumpen IN/OUT		Pompe - Pumps - Pumpen IN/OUT		
E7 E7	G7 G7	E8 E7	G8 G8	G3
G7 G7	X8 X7	G8 G8	X8 X7	G3
X8 X7		X8 X7		G3

MOTORI - MOTORS - MOTOREN OUT/IN
MOTORI BIDIR. IN=OUT - REVERS. MOTORS IN=OUT -
BIDIREK. MOTOREN IN=OUT

FLANGIA ANTERIORE
FRONT FLANGE
VORDERER FLANSCH

X - Europea D 60,3
X - European D 60,3
X - EU-Norm D 60,3

ESTREMITÀ D'ALBERO
SHAFT PROFIL
WELLENENDE

3 - Conico (1:8)
5 - Cilindrico europeo
8 - Scanalato DIN 5482
3 - Tapered (1:8)
5 - European parallel shaft
8 - DIN 5482 splined
3 - Kegel (1:8)
5 - Kegel EU-Norm
8 - Keilwelle DIN 5482

Le pompe multiple sono combinazioni di due o più sezioni trascinate da un unico albero. Il trascinamento delle sezioni che compongono la pompa multipla avviene per mezzo di giunti scanalati.

La pompa multipla così composta può avere aspirazione e mandata per ogni stadio oppure, laddove possibile, aspirazione unica e più mandate.

Per le singole sezioni valgono i valori riportati a catalogo con alcune limitazioni di pressione derivanti dalla coppia massima del giunto di trascinamento e dell'estremità di albero.

La velocità massima di una pompa multipla è limitata al valore minimo delle velocità massime delle singole sezioni.

A seguire un utile esempio per dimensionare correttamente la coppia trasmissibile all'estremità di albero e per ogni singolo stadio di una pompa tripla gruppo 3 + gruppo 3 + gruppo 2 a determinate pressioni di esercizio su ogni stadio.

ESEMPIO POMPA TRIPLA:

HPLPC336DW2E7E5B326E5E5208E3E3ST

La formula del calcolo della coppia da impiegare è:

$$M = \frac{\Delta p \cdot c}{62,83 \cdot \eta_m} \quad [Nm]$$

dove:

M = Coppia (Nm)
 ΔP = Pressione (bar)
 c = Cilindrata pompa (cm³)
 62,83 = Fattore di conversione
 η_{m} = Rendimento meccanico = 0,9

Il calcolo si svolge partendo dall'ultimo stadio della pompa risalendo fino all'albero primario. In tutti gli stadi il risultato della coppia calcolata deve essere minore o uguale alla coppia massima ammissibile di ciascun giunto di trascinamento, compreso l'estremità d'albero della pompa.

Stadio 3:

Gruppo 2, cilindrata 8,5 cm³ Pressione di funzionamento 180 bar: $M_2 = 27,06$ Nm.
 La condizione del giunto 2 è soddisfatta. (limite massimo 100 Nm).

Stadio 2:

Gruppo 3, cilindrata 26 cm³ Pressione di funzionamento 200 bar: $M_2 = 91,96$ Nm.
 $M_3 + M_2 = 119,02$ Nm.
 La condizione del giunto 1 è soddisfatta. (limite massimo 200 Nm).

Stadio 1:

Gruppo 3, cilindrata 36 cm³ Pressione di funzionamento 200 bar: $M_1 = 127,32$ Nm
 $M_3 + M_2 + M_1 = 246,34$ Nm.

Multiple pumps are combinations of two or more stages driven by one shaft. The rear pumps are driven by splined couplings.

The multiple pumps can have individual inlet and outlet ports for each stage or wherever possible a common inlet and separate outlet ports.

The technical features acc. data sheet of the present catalogue are valid for each stage, taking into consideration the limitations of transmissible torque of each coupling and the drive shaft.

The max. speed of the multiple pump is limited by the lowest max. speed of the individual stages.

Please follow the example of calculation for the correct projecting of the torque to be transmitted by the shaft and each coupling, here we calculate the admissible pressure for each stage of a triple pump consisting of group 3 + group 3 + group 2.

EXAMPLE OF TRIPLE PUMP:

HPLPC336DW2E7E5B326E5E5208E3E3ST

The calculation formula of the torque to use is:

$$M = \frac{\Delta p \cdot c}{62,83 \cdot \eta_m} \quad [Nm]$$

where:

M = Torque (Nm)
 ΔP = Pressure (bar)
 c = Pump displacement (cm³)
 62,83 = Conversion factor
 η_{m} = Mechanical efficiency = 0,9

The calculation is made from the last stage of the pump and going back as far as the main shaft. At all stages the result of the calculated torque must be less than or equal to the maximum permissible torque of each drive joint, including the pump shaft profile.

Stage 3:

Group 2, displacement 8,5 cm³ Operating pressure 180 bar: $M_2 = 27,06$ Nm
 The joint 2 condition is satisfied. (maximum limit 100 Nm).

Stage 2:

Group 3, displacement 26 cm³ Operating pressure 200 bar: $M_2 = 91,96$ Nm
 $M_3 + M_2 = 119,02$ Nm
 The joint 1 condition is satisfied. (maximum limit 200 Nm).

Stage 1:

Group 3, displacement 36 cm³ Operating pressure 200 bar: $M_1 = 127,32$ Nm
 $M_3 + M_2 + M_1 = 246,34$ Nm.

Mehrfachpumpen sind Pumpenkombinationen von mindestens zwei Stufen, die von einer Welle angetrieben werden. Die hinteren Pumpen werden von verzahnten Kupplungen angetrieben.

Mehrfachpumpen können je Stufe einen separaten Saug- und Druckanschluss haben oder, wo möglich, einen gemeinsamen Sauganschluss und getrennte Druckanschlüsse.

Die technischen Daten für die einzelnen Stufen sind entsprechend dem Datenblatt dieses Katalogs, wobei das übertragbare Drehmoment der Antriebswelle und der Zwischenkupplungen beachtet werden muß.

Die Höchstdrehzahl der Mehrfachpumpe wird bestimmt von der niedrigsten Höchstdrehzahl der einzelnen Stufen.

Um das zulässige höchste Drehmoment nicht zu überschreiten, berechnen Sie den zulässigen Betriebsdruck der einzelnen Stufen; folgen Sie dem nachfolgenden Beispiel, hier eine 3-fach Pumpe, bestehend aus einer Kombination von Gr.3 + Gr.3 + Gr.2

BEISPIEL EINER DREIFACHPUMPE:

HPLPC336DW2E7E5B326E5E5208E3E3ST

Formel zur Berechnung des erforderlichen Drehmoments:

$$M = \frac{\Delta p \cdot c}{62,83 \cdot \eta_m} \quad [Nm]$$

wobei:

M = Drehmoment (Nm)
 ΔP = Druck (bar)
 c = Fördervolumen der Pumpe (cm³)
 62,83 = Umrechnungsfaktor
 η_{m} = mechanischer Wirkungsgrad = 0,9

Die Berechnung erfolgt ausgehend von der letzten Stufe der Pumpe bis hin zur Hauptwelle. In allen Stufen muss das Ergebnis des berechneten Drehmoments kleiner oder gleich dem Wert des zulässigen Höchst Drehmoments jeder Mitnehmerwelle, einschließlich Wellenende der Pumpe, sein.

Stufe 3:

Baugröße 2, Fördervolumen 8,5 cm³, Betriebsdruck 180 bar: $M_2 = 27,06$ Nm.
 Die Bedingung der Mitnehmerwelle 2 ist erfüllt (Höchstgrenze 100 Nm).

Stufe 2:

Baugröße 3, Fördervolumen 26 cm³, Betriebsdruck 200 bar: $M_2 = 91,96$ Nm.
 $M_3 + M_2 = 119,02$ Nm.
 Die Bedingung der Mitnehmerwelle 1 ist erfüllt (Höchstgrenze 200 Nm).

Stufe 1:

Baugröße 3, Fördervolumen 36 cm³, Betriebsdruck 200 bar: $M_1 = 127,32$ Nm
 $M_3 + M_2 + M_1 = 246,34$ Nm.

La condizione dell'albero conduttore NON è soddisfatta (limite massimo 240 Nm).
 Occorre abbassare la pressione di funzionamento oppure la cilindrata, supponendo la pressione di funzionamento 180 bar $M_1 = 114.59 \text{ Nm}$.
 $M_3 + M_2 + M_1 = 233.61 \text{ Nm}$.

*The condition of the driving shaft is NOT met (max limit 240 Nm).
 The operating pressure or the capacity must be lowered, taking into consideration an operating pressure equal to 180 Bar $M_1 = 114.59 \text{ Nm}$.
 $M_3 + M_2 + M_1 = 233.61 \text{ Nm}$.*

Die Bedingung der Antriebswelle ist NICHT erfüllt (Höchstgrenze 240 Nm).
 Der Betriebsdruck oder das Fördervolumen muss verringert werden, z.B. Betriebsdruck von 180 bar: $M_1 = 114,59 \text{ Nm}$.
 $M_3 + M_2 + M_1 = 233,61 \text{ Nm}$.

La condizione dell'albero conduttore è soddisfatta (limite massimo 240 Nm).

The condition of the driving shaft is met (max limit 240 Nm).

Die Bedingung der Antriebswelle ist erfüllt (Höchstgrenze 240 Nm).

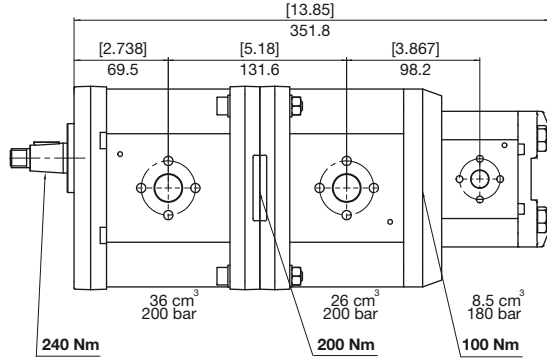

1° STADIO
STAGE
STUFE

2° STADIO
STAGE
STUFE

3° STADIO
STAGE
STUFE

1° STADIO - STAGE - STUFE

HPL **PC** **3** **36** **D** **W** **2** **E7E5** **B**

2° STADIO - STAGE - STUFE

3 **26** **E5E5**

3° STADIO - STAGE - STUFE

2 **08** **E3E3** **ST**

GIUNTO DI ACCOPIAMENTO
COUPLING JOINT
WELLENKUPPLUNG

GIUNTO DI ACCOPIAMENTO COUPLING JOINT WELLENKUPPLUNG	COPPIA MASSIMA TRASMISSIBILE MAXIMUM TRANSMITTED TORQUE MAX. ÜBERTRAGBARES DREHMOMENT
HPLP•3 + HPLP•3	200 N•m
HPLP•3 + HPLP•2 HPLP•2 + HPLP•2	100 N•m
HPLP•3 + HPLP•1 HPLP•2 + HPLP•1 HPLP•1 + HPLP•1	30 N•m

HPLP•1+HPLP•1

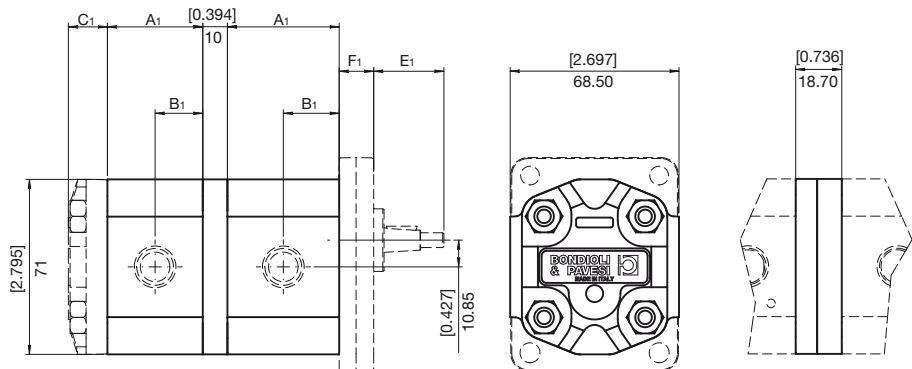

**POMPA A STADI SEPARATI
SEPARATE TANKS PUMP
UNTERSCHIEDLICHEPUMPE
BEHÄLTNER**

HPLP•2+HPLP•2

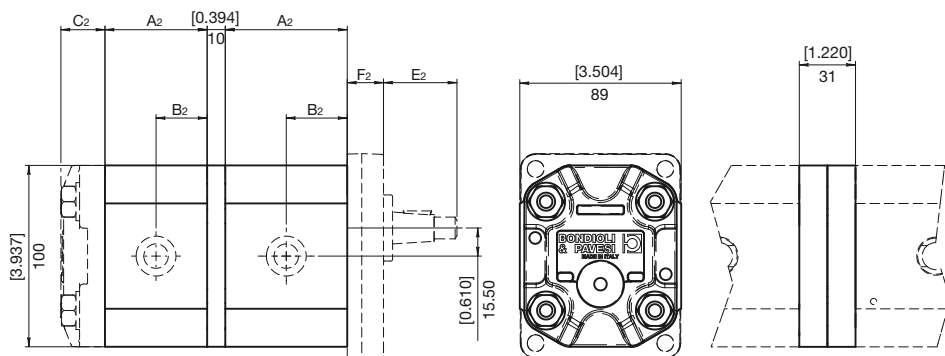

**POMPA A STADI SEPARATI
SEPARATE TANKS PUMP
UNTERSCHIEDLICHEPUMPE
BEHÄLTNER**

**DIMENSIONI
SIZE
ABMESSUNGEN**

HPLP..

HPLP•2+HPLP•1

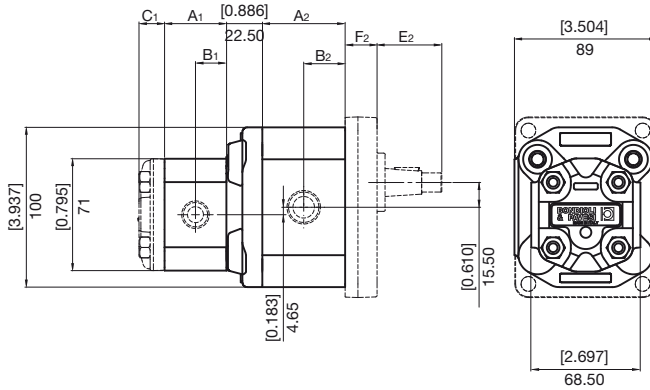

Per pompa a stadi separati le dimensioni di ingombro non variano

Separate tanks pump use same dimensions

Unterschiedlichepumpe Behälter verwenden die gleichen Masse

HPLP•3+HPLP•3

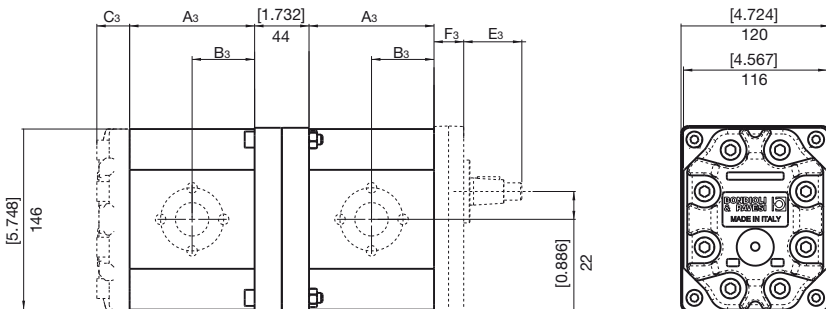

HPLP•3+HPLP•2

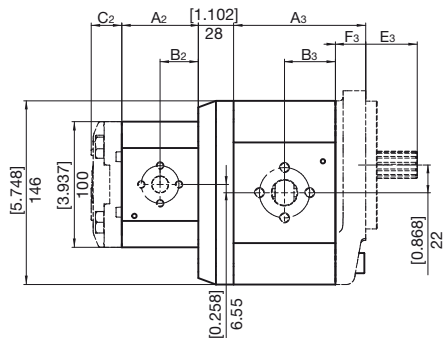

HPLP•3+HPLP•1

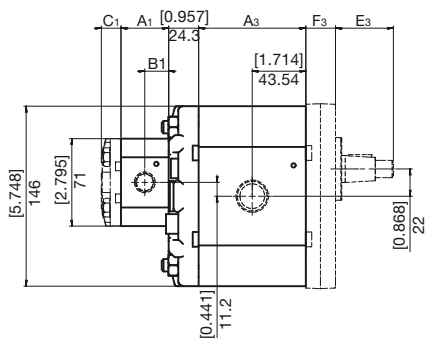

Questa pagina è intenzionalmente bianca
This page is intentionally blank
Diese Seite ist bewusst frei gelassen

1° STADIO (Descrizione dello Stadio - Stage Description - Stufe-Benennung)

HPL

PB

2

14

D

M

L

SERIE
SERIES
SERIE

PRODOTTO
PRODUCT
PRODUKT

- PB** - Pompa doppia
- PC** - Pompa tripla
- PD** - Pompa quadrupla

- PB** - Double Pump
- PC** - Triple Pump
- PD** - Quadruple Pump

- PB** - Doppelpumpe
- PC** - Dreifachpumpe
- PD** - Vierfachpumpe

GRUPPO
GROUP
BAUGRÖSSE

1 - 2 - 3 - 4

CILINDRATA
DISPLACEMENT
FÖRDERVOLUMEN

HPL..1	HPL..2	HPL..3	HPL..4
14 - 1,37	05 -4,50	22 -21,50	41 -41,80
19 - 1,9	06 -6,00	26 -26,00	51 -50,40
24 - 2,53	08 -8,50	31 -30,50	56 -55,50
31 - 3,17	11 -11,00	36 -36,00	61 -61,00
36 - 3,73	14 -14,50	41 -41,50	73 -72,00
44 - 4,35	17 -17,00	47 -46,50	90 -88,00
48 - 4,97	20 -19,50	51 -50,50	
60 - 6,08	26 -26,00	56 -56,00	
70 - 7,00	34 -34,00	61 -61,00	
80 - 7,87	40 -40,50	73 -72,00	
		90 -88,00	

SENSO DI ROTAZIONE
ROTATION
DREHRICHTUNG

S - Antioraria/sinistra
Counterclockwise
 Linkslauf

D - Oraria/destra
Clockwise
 Rechtslauf

FLANGIA ANTERIORE
FRONT FLANGE
VORDERER FLANSCH

HPL..1

- D** - Europea D 25,4
- E** - Europea D 30
- G** - Tedesca con OR
- J** - SAE AA

- D** - European standard
- E** - European D 30
- G** - German with OR
- J** - SAE AA

- D** - EU-Norm D 25,4
- E** - EU-Norm D 30
- G** - DIN-Norm (mit O.R. Dichtung)
- J** - SAE AA

HPL..2

- L** - Europea in ghisa
- M** - Europea
- N** - Tedesca
- O** - Tedesca D 50 2 fori DX
- P** - Tedesca D 50 2 fori SX
- Q** - SAE A 2 fori in ghisa
- R** - Tedesca D 52
- S** - SAE A 2 fori
- T** - SAE B 2 fori in ghisa
- U** - Perkins
- V** - Tedesca in ghisa

- L** - European cast iron
- M** - European
- N** - German
- O** - German D 50 2 holes right
- P** - German D 50 2 holes left
- Q** - SAE A 2 holes cast iron
- R** - German D 52
- S** - SAE A 2 holes
- T** - SAE B 2 holes cast iron
- U** - Perkins
- V** - German cast iron

- L** - EU-Norm Guß
- M** - EU-Norm
- N** - DIN-Norm
- O** - DIN-Norm D 50 Bohrungen rechts
- P** - DIN-Norm D 50 Bohrungen links
- Q** - SAE A 2 Bohrungen Guß
- R** - DIN-Norm D 52
- S** - SAE A 2 Bohrungen
- T** - SAE B 2 Bohrungen Guß
- U** - Perkins
- V** - Din gussversion

HPL..3

- W** - Europea D 50,8
- Z** - SAE B 2 fori
- Y** - Europea D 50,8 ghisa
- F** - SAE B 2 fori ghisa

- W** - European D 50,8
- Z** - SAE B 2 holes
- Y** - European D 50,8 cast iron
- F** - SAE B 2 holes cast iron

- W** - EU-Norm D 50,8
- Z** - SAE B 2 Bohrungen
- Y** - EU-Norm D 50,8 Guß
- F** - SAE B 2 Bohrungen Guß

HPL..4

- X** - Europea D 60,3
- X** - Europea D 60,3
- X** - EU-Norm D 60,3

ESTREMITÀ D'ALBERO
SHAFT PROFIL
WELLENENDE

HPL..1

- D** - Conico (1:8)
- E** - Cilindrico europeo
- F** - Cilindrico SAE "AA"
- G** - Conico (1:5)
- H** - Scanalato 12x9
- I** - Scanalato SAE "AA"
- J** - Dente frontale sporgente
- K** - Dente frontale
- L** - Conico high torque (1:8)
- D** - Tapered (1:8)
- E** - European parallel shaft
- F** - SAE "AA" parallel shaft
- G** - Tapered (1:5)
- H** - Splined 12x9
- I** - SAE "AA" splined
- J** - Front tooth
- K** - Tang drive
- T** - Tapered high torque (1:8)
- D** - Kegel (1:8)
- E** - zylindrisch (E-norm)
- F** - zylindrisch SAE "AA"
- G** - Kegel (1:5)
- H** - Keilwelle 12x9
- I** - Keilwelle SAE "AA"
- J** - Vorstehendes Kreuzprofil
- K** - Kreuzprofil
- T** - verstärkter Kegel (1:8)

HPL..2

- L** - Conico (1:8)
- M** - Conico (1:5)
- N** - Cilindrico D15 europeo
- P** - Cilindrico SAE "A"
- U** - Scanalato DIN 5482
- V** - Scanalato SAE "A" 9T
- X** - Scanalato SAE "A" 11T
- Y** - Scanalato SAE "B" 13T
- Z** - Dente frontale
- L** - Tapered (1:8)
- M** - Tapered (1:5)
- N** - D15 European parallel shaft
- P** - SAE "A" parallel shaft
- U** - DIN 5482 splined
- V** - SAE "A" 9t splined
- X** - SAE "A" 11t splined
- Y** - SAE "B" 13t splined
- Z** - Tang drive
- L** - Kegel (1:8)
- M** - Kegel (1:5)
- N** - zylindrisch (E-norm)
- P** - zylindrisch SAE "A"
- U** - Keilwelle DIN 5482
- V** - Keilwelle SAE "A" 9T
- X** - Keilwelle SAE "A" 11T
- Y** - Keilwelle SAE "B" 13T
- Z** - Kreuzprofil

HPL..3

- 1** - Scanalato SAE "BB" 15T
- 2** - Conico (1:8)
- 4** - Cilindrico europeo
- 6** - Cilindrico SAE "B"
- 7** - Scanalato DIN 5482
- 9** - Scanalato SAE "B" 13T
- 1** - SAE "BB" 15T Splined
- 2** - Tapered (1:8)
- 4** - European parallel shaft
- 6** - SAE "B" parallel shaft
- 7** - DIN 5482 splined
- 9** - SAE "B" 13T splined
- 1** - Keilwelle SAE "BB" 15T
- 2** - Kegel (1:8)
- 4** - Kegel EU-Norm
- 6** - zylindrisch SAE "B"
- 7** - Keilwelle DIN 5482
- 9** - Keilwelle SAE "B" 13T

HPL..4

- 3** - Conico (1:8)
- 5** - Cilindrico europeo
- 8** - Scanalato DIN 5482
- 3** - Tapered (1:8)
- 5** - European parallel shaft
- 8** - DIN 5482 splined
- 3** - Kegel (1:8)
- 5** - zylindrisch EU-Norm
- 8** - Keilwelle DIN 5482



STADI SUCCESSIVI - FOLLOWING STAGES - FOLGESTUFEN
(Descrizione dello Stadio - Stage Description - Stufe Benennung)



BOCCHES STD - STANDARD PORT - STANDARD ANSCHLÜSSE
CILINDRATA - DISPLACEMENT - FÖRDER-/SCHLUCKVOLUMEN

HPL..1
CILINDRATA - DISPLACEMENT - FÖRDER-/SCHLUCKVOLUMEN

1,4.....4,8		6.....8		1,4.....4,8		6.....8	
Pompe - Pumps	Pumpen IN/OUT	Pompe - Pumps	Pumpen IN/OUT	Pompe - Pumps	Pumpen IN/OUT	Pompe - Pumps	Pumpen IN/OUT
E3 E3	E3 E3	E3 E3	E3 E3	U3 U3	U3 U3	U4 U4	U4 U4
G3 G3	G4 G4						
X3 X3	X3 X3						
M4 M2	M4 M2						

HPL..2
CILINDRATA - DISPLACEMENT - FÖRDER-/SCHLUCKVOLUMEN

5.....8		11		14.....20		26		34.....40	
Pompe - Pumps	Pumpen IN/OUT	Pompe - Pumps	Pumpen IN/OUT	Pompe - Pumps	Pumpen IN/OUT	Pompe - Pumps	Pumpen IN/OUT	Pompe - Pumps	Pumpen IN/OUT
E3 E3	E3 E3	E5 E3	E5 E3	E5 E5	E5 E5	E5 E5	E5 E5	E5 E5	E5 E5
G4 G4	G4 G4	G6 G4	G6 G4	G6 G6	G6 G6	G7 G6	G7 G6	G7 G6	G7 G6
X5 X4	X6 X4	X6 X4	X6 X4	X6 X5	X6 X5	X8 X6	X8 X6	X8 X6	X8 X6
U6 U5	U6 U5	U6 U5	U6 U5	U6 U5	U6 U5	U7 U6	U7 U6	U7 U6	U7 U6
N4 N4	N4 N4	N6 N4	N6 N4	N7 N6	N7 N6	N7 N6	N7 N6	N7 N6	N7 N6

HPL..3
CILINDRATA - DISPLACEMENT - FÖRDER-/SCHLUCKVOLUMEN

22.....31		36.....61		73.....90	
Pompe - Pumps	Pumpen IN/OUT	Pompe - Pumps	Pumpen IN/OUT	Pompe - Pumps	Pumpen IN/OUT
E5 E5	E5 E5	E7 E5	E7 E5	E8 E7	E8 E7
G6 G6	G6 G6	G7 G6	G7 G6	G8 G7	G8 G7
U7 U6	U7 U6	U8 U7	U8 U7	U8 U7	U8 U7
N7 N6	N7 N6	N7 N6	N7 N6	N8 N7	N8 N7
X8 X7	X8 X7	X8 X7	X8 X7	X8 X7	X8 X7

HPL..4
CILINDRATA - DISPLACEMENT - FÖRDER-/SCHLUCKVOLUMEN

41.....61		73.....90	
Pompe - Pumps	Pumpen IN/OUT	Pompe - Pumps	Pumpen IN/OUT
E7 E7	E7 E7	E8 E7	E8 E7
G7 G7	G7 G7	G8 G8	G8 G8
X8 X7	X8 X7	X8 X7	X8 X7

- * Versione EU stadio successivo al primo IN = SF
- * EU version following stage IN = SF
- * EU Version Folgestufen IN = SF

SET VALVOLE
VALVE SETTING
VENTILEINSTELLUNG
(bar)

COPERCHI COVERS DECKEL
ST - Standard
V. - Con valvole (Vedi sez. valvole) With valves (See valves section) Mit Ventilen (siehe Abschnitt Ventile)
SG - versione in ghisa. Non disponibile per il Gruppo 1 Cast iron version Not available for Group 1 Gussversion Nicht vorhanden für Gruppe 1
EU* - Entrata unica Common inlet Geläufiger Eingang

BOCCHES PORT ANSCHLÜSSE

CILINDRATA DISPLACEMENT FÖRDERVOLUMEN

GRUPPO GROUP BAUGRÖSSE

SERIE
SERIES
SERIE
L-HPL
Z-HPZ

GUARNIZIONI SEALS DICHTUNGEN

- B - NBR
- R - NBR alte pres. (picco 25 bar) For high pres. (peak 25 bar) Hochdruck (spitzen 25 bar)
- S - NBR stadi separati. Non disponibile per il Gruppo 3 separate tanks. Not available for Group 3 unterschiedliche Behälter. Nicht vorhanden für Gruppe 3
- T - HNBR stadi separati. Non disponibile per il Gruppo 3 separate tanks. Not available for Group 3 unterschiedliche Behälter. Nicht vorhanden für Gruppe 3
- X - VITON stadi separati. Non disponibile per il Gruppo 3 separate tanks. Not available for Group 3 unterschiedliche Behälter. Nicht vorhanden für Gruppe 3
- V - Viton
- W - Viton alte pres. (picco 25 bar) For high pres. (peak 25 bar) Hochdruck (spitzen 25 bar)

PER OGNI STADIO AGGIUNTO RIPETERE LA DESCRIZIONE **DESCRIPTION TO BE REPEATED FOR EVERY ADDED SECTION** **FÜR JEDE STUFE BITTE DIE BESCHREIBUNG WIEDERHOLEN.**

HPLPT

POMPE PREDISPOSTE E RELATIVI KIT PUMPS PREPARED FOR ASSEMBLY OF MULTIPLE PUMPS PUMPEN MIT DURCHTRIEB

KIT ASSEMBLAGGIO POMPE PT ASSEMBLY KIT (PT PUMPS ONLY) TANDEM-SATZ (NUR PT-PUMPEN)

Le pompe PT sono pompe singole, che possono essere assemblate rapidamente e facilmente con l'impiego DEGLI APPOSITI KIT.

- **HPLKA11STR** per l'assemblaggio di pompe Gruppo 1.
- **HPLKA21STR** per l'assemblaggio di pompe Gruppo 2 e 1.
- **HPLKA21AMR** per l'assemblaggio di pompe Gruppo 2 e 1 SAE.
- **HPLKA21DER** per l'assemblaggio di pompe Gruppo 2 e 1 versione tedesca.
- **HPLKA21ASR** per l'assemblaggio di pompe Gruppo 2 e 1 drenaggi separati.
- **HPLKA21S1R** per l'assemblaggio di pompe Gruppo 2 e 1 drenaggi separati SAE.
- **HPLKA22STR** per l'assemblaggio di pompe Gruppo 2.
- **HPLKA22ASR** per l'assemblaggio di pompe Gruppo 2 e 2 drenaggi.
- **HPLKA33S1R** per l'assemblaggio di pompe Gruppo 3.
- **HPLKA44S1R** per l'assemblaggio di pompe Gruppo 3.
- **HPLKA32S1R** per l'assemblaggio di pompe Gruppo 3 e 2.
- **HPLKA31S1R** per l'assemblaggio di pompe Gruppo 3 e 1.

PT pumps are single pumps that can be quickly and easily assembled using THE DEDICATED ASSEMBLY KIT.

- **HPLKA11STR**
Group 1 assembly
- **HPLKA21STR**
Group 2 and 1 assembly
- **HPLKA21AMR**
Group 2 and 1 SAE assembly
- **HPLKA21DER**
Group 2 and 1 German version
- **HPLKA21ASR**
Group 2 and 1 separate drain assembly
- **HPLKA21S1R**
Group 2 and 1 SAE separate drain assembly
- **HPLKA22STR**
Group 2 assembly
- **HPLKA22ASR**
Group 2 and 2 drains assembly
- **HPLKA33S1R**
Group 3 assembly.
- **HPLKA44S1R**
Group 3 assembly.
- **HPLKA32S1R**
Group 3 and 2 assembly
- **HPLKA31S1R**
Group 3 and 1 assembly

Die PT-Pumpen sind Einfachpumpen, die schnell zu Mehrfachpumpen umgebaut werden können - unter Verwendung der dazugehörigen Tandem-Sätze

- **HPLKA11STR** Für den Zusammenbau der Pumpen Gruppe 1.
- **HPLKA21STR** Für den Zusammenbau der Pumpen Gruppe 2 und 1.
- **HPLKA21AMR** Für den Zusammenbau der SAE-Pumpen Gruppe 2 und 1.
- **HPLKA21DER** Für den Zusammenbau der Gruppe 2 und 1 Din-Version.
- **HPLKA21ASR** Für den Zusammenbau der Pumpen Gruppe 2 und 1 Leckölanschluss separat.
- **HPLKA21S1R** Für den Zusammenbau der Pumpen Gruppe 2 und 1 SAE-Leckölanschluss separat.
- **HPLKA22STR** Für den Zusammenbau der Pumpen Gruppe 2.
- **HPLKA22ASR** Für den Zusammenbau der Pumpen Gruppe 2 und 2 Leckölanschlüsse.
- **HPLKA33S1R** Für den Zusammenbau der Pumpen Gruppe 3.
- **HPLKA44S1R** Für den Zusammenbau der Pumpen Gruppe 3.
- **HPLKA32S1R** Für den Zusammenbau der Pumpen Gruppe 3 und 2.
- **HPLKA31S1R** Für den Zusammenbau der Pumpen Gruppe 3 und 1.

HPLPT1...

+

HPLPT1...

+

HPLKA11STR

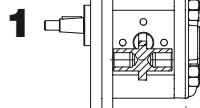

1
SMONTAGGIO
REMOVE
DEMONTIEREN

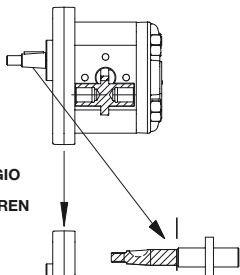

2
SMONTAGGIO
REMOVE
DEMONTIEREN

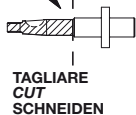

TAGLIARE
CUT
SCHNEIDEN

2

MONTAGGIO
REASSEMBLE
MONTAGE

3

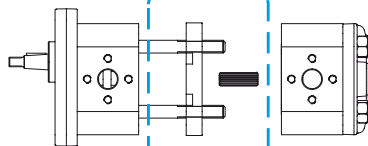

HPLKA11STR
KIT - SATZ

FLANGIA
FLANGE
FLANSCH

GIUNTO
JOINT
WELLE

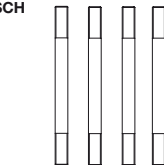

VITI STANDARD
STANDARD SCREWS
STANDARD SCHRAUBEN

HPLKA11STR
KIT - SATZ

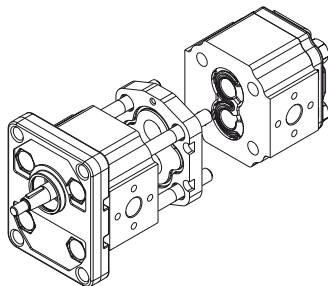

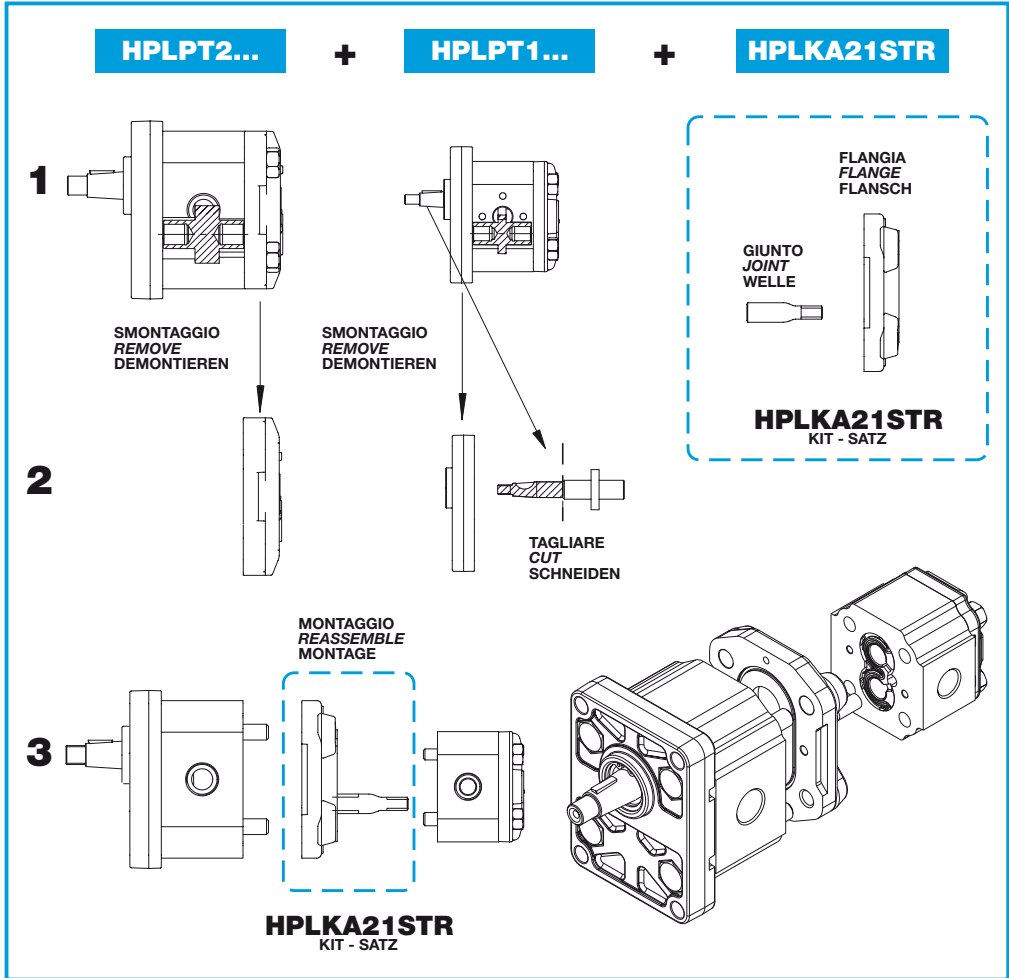

VERSIONE SAE
SAE VERSION
SAE-VERSION



VERSIONE TEDESCA
GERMAN VERSION
DIN-VERSION



**KIT ASSEMBLAGGIO POMPE PT
ASSEMBLY KIT (PT PUMPS ONLY)
TANDEM-SATZ (NUR PT-PUMPEN)**

HPLPT2...

+

HPLPT2...

+

HPLKA22STR

1

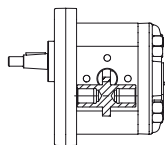

**SMONTAGGIO
REMOVE
DEMONTIEREN**

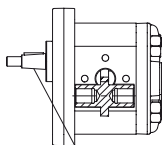

**SMONTAGGIO
REMOVE
DEMONTIEREN**

2

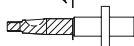

**TAGLIARE
CUT
SCHNEIDEN**

**FLANGIA
FLANGE
FLANSCH**

**GIUNTO
JOINT
WELLE**

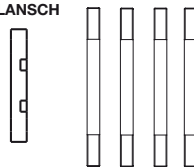

**VITI STANDARD
STANDARD SCREWS
STANDARD SCHRAUBEN**

**HPLKA22STR
KIT - SATZ**

3

**MONTAGGIO
REASSEMBLE
MONTAGE**

**TAGLIARE
CUT
SCHNEIDEN**

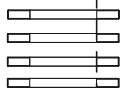
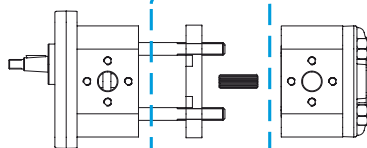

**HPLKA22STR
KIT - SATZ**

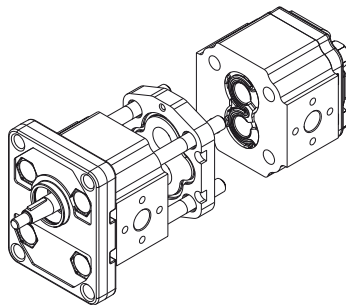



**KIT ASSEMBLAGGIO POMPE PT
ASSEMBLY KIT (PT PUMPS ONLY)
TANDEM-SATZ (NUR PT-PUMPEN)**

HPLPT3...

+

HPLPT3...

+

HPLKA33S1R

HPLPT4...

+

HPLPT4...

+

HPLKA44S1R

1

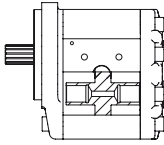

**SMONTAGGIO
REMOVE
DEMONTIEREN**

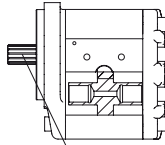

**SMONTAGGIO
REMOVE
DEMONTIEREN**

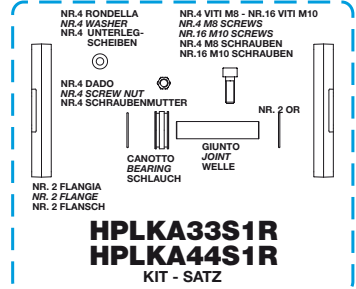

2



**TAGLIARE
CUT
SCHNEIDEN**

3

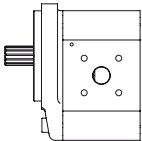

**MONTAGGIO
REASSEMBLE
MONTAGE**

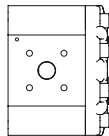
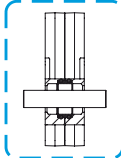

**HPLKA33S1R
HPLKA44S1R**

KIT - SATZ

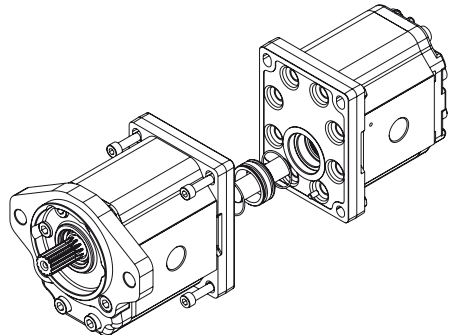

**KIT ASSEMBLAGGIO POMPE PT
ASSEMBLY KIT (PT PUMPS ONLY)
TANDEM-SATZ (NUR PT-PUMPEN)**

HPLPT3...

+

HPLPT2...

+

HPLKA32S1R

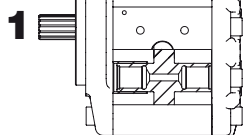

**SMONTAGGIO
REMOVE
DEMONTIEREN**

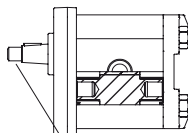

**SMONTAGGIO
REMOVE
DEMONTIEREN**

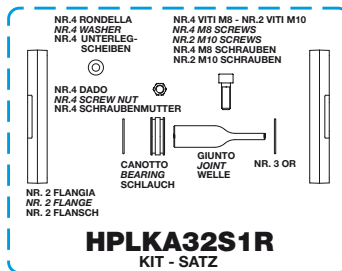

2

**TAGLIARE
CUT
SCHNEIDEN**

**MONTAGGIO
REASSEMBLE
MONTAGE**

3

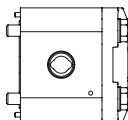
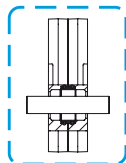
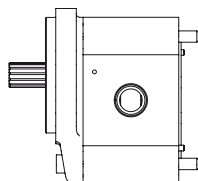

**HPLKA32S1R
KIT-SATZ**

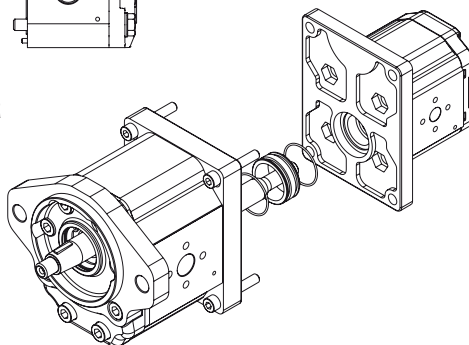



**KIT ASSEMBLAGGIO POMPE PT
ASSEMBLY KIT (PT PUMPS ONLY)
TANDEM-SATZ (NUR PT-PUMPEN)**

HPLPT3...

+

HPLPT1...

+

HPLKA31S1R

1

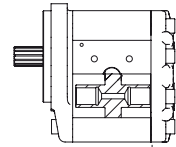

SMONTAGGIO
REMOVE
DEMONTIEREN

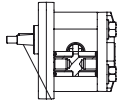

SMONTAGGIO
REMOVE
DEMONTIEREN

NR.2 VITI M10
NR.2 M10 SCREWS
NR.2 M10 SCHRAUBEN



GIUNTO
JOINT
WELLE



FLANGIA
FLANGE
FLANSCH

HPLKA31S1R
KIT - SATZ

2



TAGLIARE
CUT
SCHNEIDEN

3

MONTAGGIO
REASSEMBLE
MONTAGE

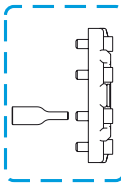
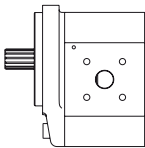

HPLKA31S1R
KIT - SATZ

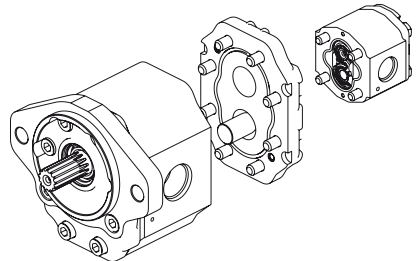

POMPE E MOTORI CON VALVOLE INTEGRATE
INTEGRATED VALVES FOR PUMP AND MOTORS
PUMPEN UND MOTOREN MIT INTEGRIERTEN VENTILEN

Con lo scopo di integrare più funzioni in un unico componente il circuito idraulico e quindi per ridurre anche la circuitistica d'impianto è possibile incorporare nel coperchio della pompa e/o del motore alcuni tipi di valvole di controllo della portata (valvole prioritarie) e della pressione oltre a valvole di non ritorno. Per ottenere informazioni più accurate della gamma di personalizzazioni si prega di contattare il nostro servizio tecnico-commerciale.

To integrate many functions into a single component of the hydraulic circuit and to limit the installation circuitry, it is possible to have some types of flow control valves (priority valves), pressure control valves, and check valves incorporated into the pump/motor cover.

For further information about the series of customized solutions, please contact our Technical and Commercial Department.

Um mehrere Funktionen in einem einzigen Bauteil des Hydraulikkreislaufs zusammenzufassen und, um die Anzahl der Bauteile zu reduzieren, können in den Deckel der Pumpe und/oder des Motors einige Ventiltypen zur Regelung von Durchfluss (Prioritätsventile) und Druck sowie Rückschlagventile integriert werden. Für nähere Informationen über die Möglichkeiten der Anpassung an Ihre Bedürfnisse wenden Sie sich bitte an unseren technischen Kundendienst und Vertrieb.

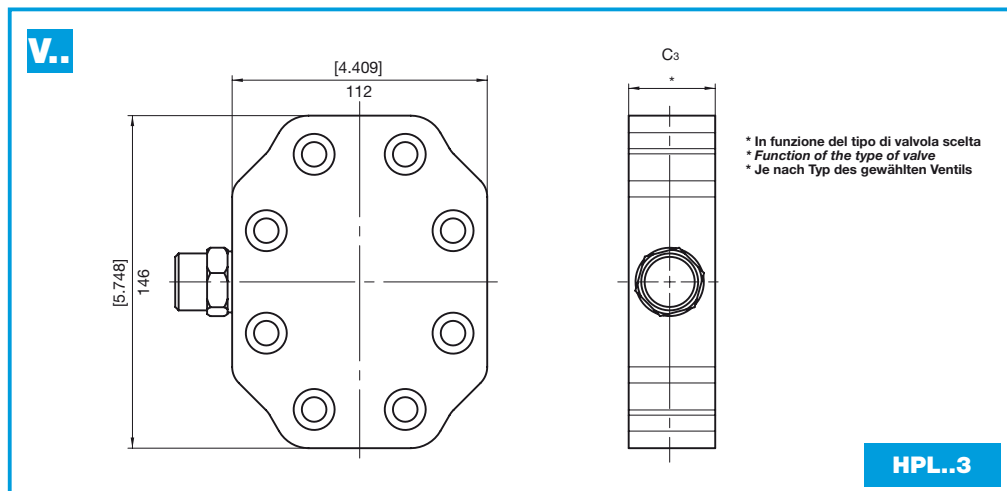
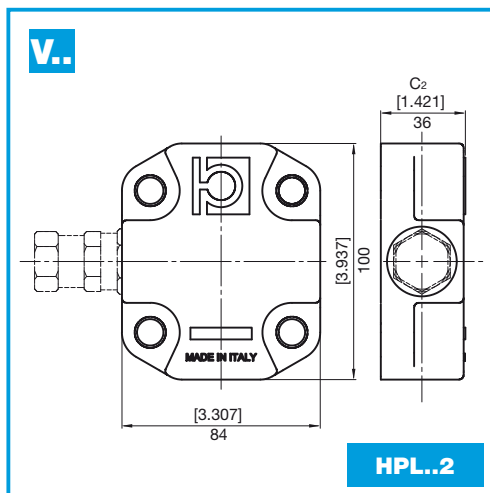
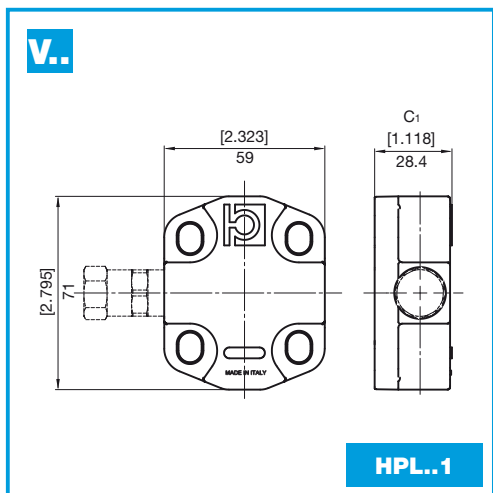



**VALVOLE
VALVES
VENTILE**

VA



**VALVOLA ANTICAVITAZIONE
ANTI-CAVITATION CHECK VALVE
RÜCKSCHLAGVENTIL**

VB



**VALVOLA LIMITATRICE DI PRESSIONE A TARATURA FISSA CON VALVOLA ANTICAVITAZIONE DRENAGGIO INTERNO
ANTI-CAVITATION CHECK VALVE AND RELIEF VALVE WITH INTERNAL DRAIN
FESTEINGESTELLTES DRUCKBEGRENZUNGSVENTIL MIT INTERNEM LECKÖL**

VC



**VALVOLA LIMITATRICE DI PRESSIONE A TARATURA FISSA CON VALVOLA ANTICAVITAZIONE DRENAGGIO ESTERNO
ANTI-CAVITATION CHECK VALVE AND RELIEF VALVE WITH EXTERNAL DRAIN
FESTEINGESTELLTES DRUCKBEGRENZUNGSVENTIL MIT EXTERNEM LECKÖL**

VD



**VALVOLA LIMITATRICE DI PRESSIONE DIRETTA REGOLABILE A DRENAGGIO INTERNO
PRESSURE RELIEF VALVE WITH INTERNAL DRAIN
EINSTELLBARES DRUCKBEGRENZUNGSVENTIL MIT INTERNEM LECKÖL**

VE



**VALVOLA LIMITATRICE DI PRESSIONE DIRETTA REGOLABILE A DRENAGGIO ESTERNO
PRESSURE RELIEF VALVE WITH EXTERNAL DRAIN
EINSTELLBARES DRUCKBEGRENZUNGSVENTIL MIT EXTERNEM LECKÖL**

VT



**VALVOLA LIMITATRICE DI PRESSIONE DIRETTA REGOLABILE A DRENAGGIO INTERNO CON VALVOLA ANTICAVITAZIONE
PRESSURE RELIEF VALVE WITH INTERNAL DRAIN WITH ANTI-CAVITATION CHECK VALVE
EINSTELLBARES DRUCKBEGRENZUNGSVENTIL MIT INTERNEM LECKÖL MIT RÜCKSCHLAGVENTIL**

POMPE CON VALVOLA PRIORITARIA PRIORITY VALVE PUMPS PUMPE MIT PRIORITÄTSENTIL

Pompe ad ingranaggi HPLPA2 con valvola prioritaria integrata nel coperchio.

Gear pumps HPLPA2 with priority valve integrated in the cover.

Zahnradpumpen HPLPA2 mit im Deckel integriertem Prioritätsventil.

PRINCIPIO DI FUNZIONAMENTO:

La pompa con valvola prioritaria permette di avere a disposizione una portata di olio costante PF indipendentemente dalla variazione di pressione e di velocità della pompa. La portata in eccesso EF, funzione della velocità di rotazione, può essere scaricata internamente alla pompa in aspirazione, oppure diretta agli ausiliari. Il circuito a cui è indirizzata la portata prioritaria PF ha la priorità rispetto al secondario che riceve solamente la portata eccedente EF.

Tutte le porte possono essere pressurizzate. Esistono diverse possibilità di configurazione della valvola prioritaria, tutte integrate nel coperchio (vedi "Istruzione per l'ordinazione").

OPERATING PRINCIPLE:

The pump with priority valve allows a constant oil flow PF irrespective of the variation in pressure and speed of the pump. The excess flow EF, depending on the rotation speed, may be discharged into the suction pump or sent to the auxiliaries.

The circuit to which the priority flow PF is sent has priority over the secondary circuit which receives only the excess flow EF.

All ports may be pressurised.

There are various possibilities of configuration of the priority valve, all integrated in the cover (see "Ordering instructions").

FUNKTIONSPRINZIP:

Die Pumpe mit Prioritätsventil ermöglicht die Bereitstellung eines konstanten Ölolumens PF unabhängig von der Änderung des Drucks und der Drehzahl der Pumpe. Das von der Drehzahl abhängige überschüssige Volumen EF kann intern zur Saugpumpe abgelassen oder zu den Hilfsvorrichtungen geleitet werden. Der Kreislauf, dem das Prioritätsvolumen PF vorbehalten ist, hat Priorität gegenüber dem sekundären Kreislauf, der nur das überschüssige Volumen EF aufnimmt.

Alle Anschlüsse können unter Druck gesetzt werden. Es gibt verschiedene Möglichkeiten der Konfiguration des Prioritätsventils, die alle im Deckel integriert sind (siehe "Bestellanleitung").

V..

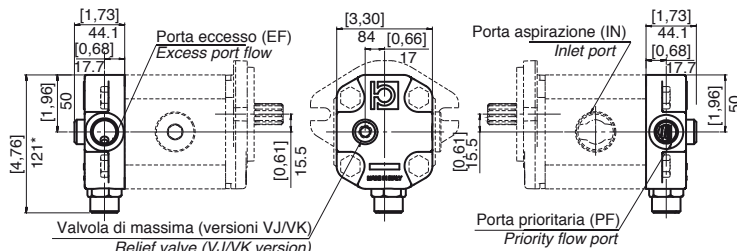

- * per versioni con valvola prioritaria tarabile quota massima = 178,5 mm
- * for versions with settable priority valve maximum size = 178,5 mm
- * für Versionen mit einstellbarem Prioritätsventil - Höchstwert = 178,5 mm

HPL..2

VALVOLA PRIORITARIA PRIORITY VALVE PRIORITÄTSENTIL

VF



VALVOLA REGOLATRICE DI FLUSSO COMPENSATA A TARATURA FISSA CON RICIRCOLO PORTATA RESIDUA
FIXED PRIORITY FLOW DIVIDER, 2-WAY
FESTEINGESTELLTES DRUCKKOMPENSIERTES STROMREGELVENTIL MIT RESTÖLUMLAUF

VG



VALVOLA REGOLATRICE DI FLUSSO COMPENSATA CON RICIRCOLO PORTATA RESIDUA
ADJUSTABLE PRIORITY FLOW DIVIDER, 2-WAY
EINSTELLBARES DRUCKKOMPENSIERTES STROMREGELVENTIL MIT RESTÖLUMLAUF

VH



VALVOLA REGOLATRICE DI FLUSSO COMPENSATA A TARATURA FISSA
FIXED PRIORITY FLOW DIVIDER, 3-WAY
FESTEINGESTELLTES 3-WEGE-STROM-REGELVENTIL MIT DRUCKKOMPENSATION

VI



VALVOLA REGOLATRICE DI FLUSSO COMPENSATA
ADJUSTABLE PRIORITY FLOW DIVIDER, 3-WAY
FESTEINGESTELLTES 3-WEGE-STROM-REGELVENTIL MIT DRUCKKOMPENSATION

VJ



VALVOLA REGOLATRICE DI FLUSSO COMPENSATA A TARATURA FISSA CON CONTROLLO DI PRESSIONE SU PORTATA COSTANTE
FIXED PRIORITY FLOW DIVIDER, 3-WAY WITH RELIEF ON PRIORITY FLOW
FESTEINGESTELLTES KOMPENSIERTES STROMREGELVENTIL MIT DRUCKBEGRENZUNGSVENTIL

VK



VALVOLA REGOLATRICE DI FLUSSO COMPENSATA CON CONTROLLO DI PRESSIONE SU PORTATA COSTANTE
ADJUSTABLE PRIORITY FLOW DIVIDER, 3-WAY WITH RELIEF ON PRIORITY FLOW
FESTEINGESTELLTES KOMPENSIERTES STROMREGELVENTIL MIT DRUCKBEGRENZUNGSVENTIL



ISTRUZIONI PER L'ORDINAZIONE
ORDERING INSTRUCTIONS
BESTELLANLEITUNG

HPL PA 2 11 D M L U6 U5 B VK 12 130 U

SERIE
SERIES
SERIE

PRODOTTO
PRODUCT
PRODUKT

PA - Pompa singola
PA - Pump
PA - Pumpe

GRUPPO
GROUP
BAUGRÖSSE

2

CILINDRATA
DISPLACEMENT
FÖRDERVOLUMEN

05 - 4,50
06 - 6,00
08 - 8,50
11 - 11,00
14 - 14,50
17 - 17,00
20 - 19,50
26 - 26,00

DESCRIZIONE
DESCRIPTION
BENENNUNG

HPLPA2

Vedere pagina GL016_27
See page GL016_27
Siehe Seite GL016_27

BOCCHE
PORT
ANSCHLÜSSE

	5.....11		14.....26	
	EF	PF	EF	PF
G	G3	G3	G4	G4
U	U5	U4	U5	U4

OPZIONI
OPTIONS
OPTIONEN

Per versioni VJ e VK indicare valore della taratura (bar) della valvola di massima

For versions VJ and VK, indicate the relief valve setting value (bar)

Für die Versionen VJ und VK den Einstellwert (bar) des Druckbegrenzungsventils angeben

PORTATA PRIORITARIA
PRIORITY FLOW
PRIORITÄT VOLUMEN

-- Indicare il valore della portata prioritaria (l/min)

-- Indicate priority flow rate (l/min)

-- Wert des Prioritätsvolumens angeben (l/min)

VALVOLA PRIORITARIA
PRIORITY VALVE
PRIORITÄTSVENTIL

VF - Valvola regolatrice di flusso compensata a taratura fissa con ricircolo portata residua

VG - Valvola regolatrice di flusso compensata con ricircolo portata residua

VH - Valvola regolatrice di flusso compensata a taratura fissa

VI - Valvola regolatrice di flusso compensata

VJ - Valvola regolatrice di flusso compensata a taratura fissa con controllo di pressione su portata costante

VK - Valvola regolatrice di flusso compensata con controllo di pressione su portata costante

VF - Fixed priority flow divider, 2-way

VG - Adjustable priority flow divider, 2-way

VH - Fixed priority flow divider, 3-way

VI - Adjustable priority flow divider, 3-way

VJ - Fixed priority flow divider, 3-way with relief on priority flow

VK - Adjustable priority flow divider, 3-way with relief on priority flow

VF - Festeingestelltes druckkompensiertes stromregelventil mit restölumlauf

VG - Einstellbares druckkompensiertes stromregelventil mit restölumlauf

VH - Festeingestelltes 3-wege-strom-regelventil mit druckkompensation

VI - Festeingestelltes 3-wege-strom-regelventil mit druckkompensation

VJ - Festeingestelltes kompensiertes stromregelventil mit druckbegrenzungsventil

VK - Festeingestelltes kompensiertes stromregelventil mit druckbegrenzungsventil

**POMPE LOAD SENSING
LOAD SENSING PUMP
LOAD SENSING PUMPE**

Pompe ad ingranaggi serie HPLPA2 e HPLPA3 con load sensing integrato nel coperchio posteriore. Il sistema è utilizzato principalmente per comandare unità idroguida load sensing oppure distributori load sensing.

Gear pumps series HPLPA2 and HPLPA3 with load sensing integrated in the rear cover. The system is used mainly to control load sensing power steering units or load sensing distributors.

Zahnradpumpen der Baureihen HPLPA2 und HPLPA3 mit im hinteren Deckel integriertem Load Sensing. Das System dient in erster Linie zur Steuerung von Load Sensing Hydrolenkungseinheiten oder Load Sensing Steuergeräten.

PRINCIPIO DI FUNZIONAMENTO:

Il sistema, prelevando il segnale dall'idroguida LS o dal distributore LS, fornisce la portata (CF) necessaria all'idroguida nella situazione di carico in cui essa si trova indipendentemente dal numero di giri, garantendone sempre il corretto funzionamento e lavorando alla pressione richiesta dal carico. La portata eccedente (EF) è indirizzata ai servizi. Quando l'idroguida è in condizioni di riposo tutta la portata (EF) è fornita ai servizi.

Load sensing statico: deve essere utilizzata con unità idroguida o distributori load sensing statici.

Load sensing dinamica: deve essere utilizzata con unità idroguida o distributori load sensing dinamici.

OPERATING PRINCIPLE:

Receiving the signal from the LS power steering or from the LS distributor, the system supplies the necessary flow (CF) to the power steering in the current load situation, irrespective of the number of revs, always ensuring correct operation and working at the required load pressure. The excess flow (EF) is sent to the utilities. When the power steering is in rest conditions, the whole flow (EF) is sent to the utilities.

Static load sensing: must be used with static power steering units or load sensing distributors.

Dynamic load sensing: must be used with dynamic power steering units or load sensing distributors.

FUNKTIONSPRINZIP:

Beim Eingang des Signals von der LS Hydrolenkung oder vom LS Steuergerät liefert das System das erforderliche Volumen (CF) an die Hydrolenkung im Lastzustand, in der sich diese unabhängig von der Drehzahl befindet, und gewährleistet somit stets deren korrekte Funktionsweise mit dem von der Last geforderten Druck. Das überschüssige Volumen (EF) geht hierbei an die Verbraucher. Ist die Hydrolenkung im Ruhestatus, wird das gesamte Volumen (EF) an die Verbraucher geleitet.

Statisches Load Sensing: Nutzung nur mit statischen Load Sensing Hydrolenkungseinheiten oder Steuergeräten.

Dynamisches Load Sensing: Nutzung nur mit dynamischen Load Sensing Hydrolenkungseinheiten oder Steuergeräten.

S

**LOAD SENSING STATICO
LOAD SENSING STATIC
STATIC LOAD SENSING**

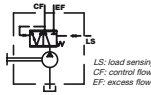

LS: load sensing signal
CF: control flow
EF: excess flow

**LOAD SENSING DINAMICO
LOAD SENSING DYNAMIC
DYNAMIC LOAD SENSING**

D

HPLP.2

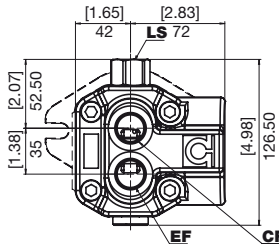

P BOCCHIE POSTERIORI
REAR PORTS
HINTEN ANSCHLÜSSE

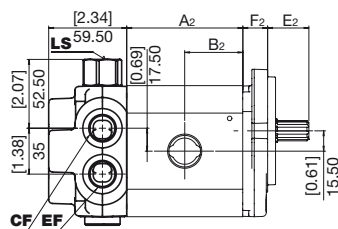

L BOCCHIE LATERALI
LATERAL PORTS
SEITLICH ANSCHLÜSSE

HPLP.3

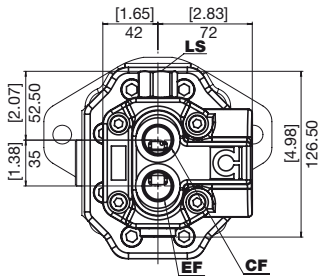

P BOCCHIE POSTERIORI
REAR PORTS
HINTEN ANSCHLÜSSE

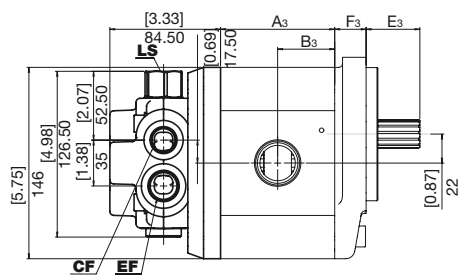

L BOCCHIE LATERALI
LATERAL PORTS
SEITLICH ANSCHLÜSSE



ISTRUZIONI PER L'ORDINAZIONE
ORDERING INSTRUCTIONS
BESTELLANLEITUNG

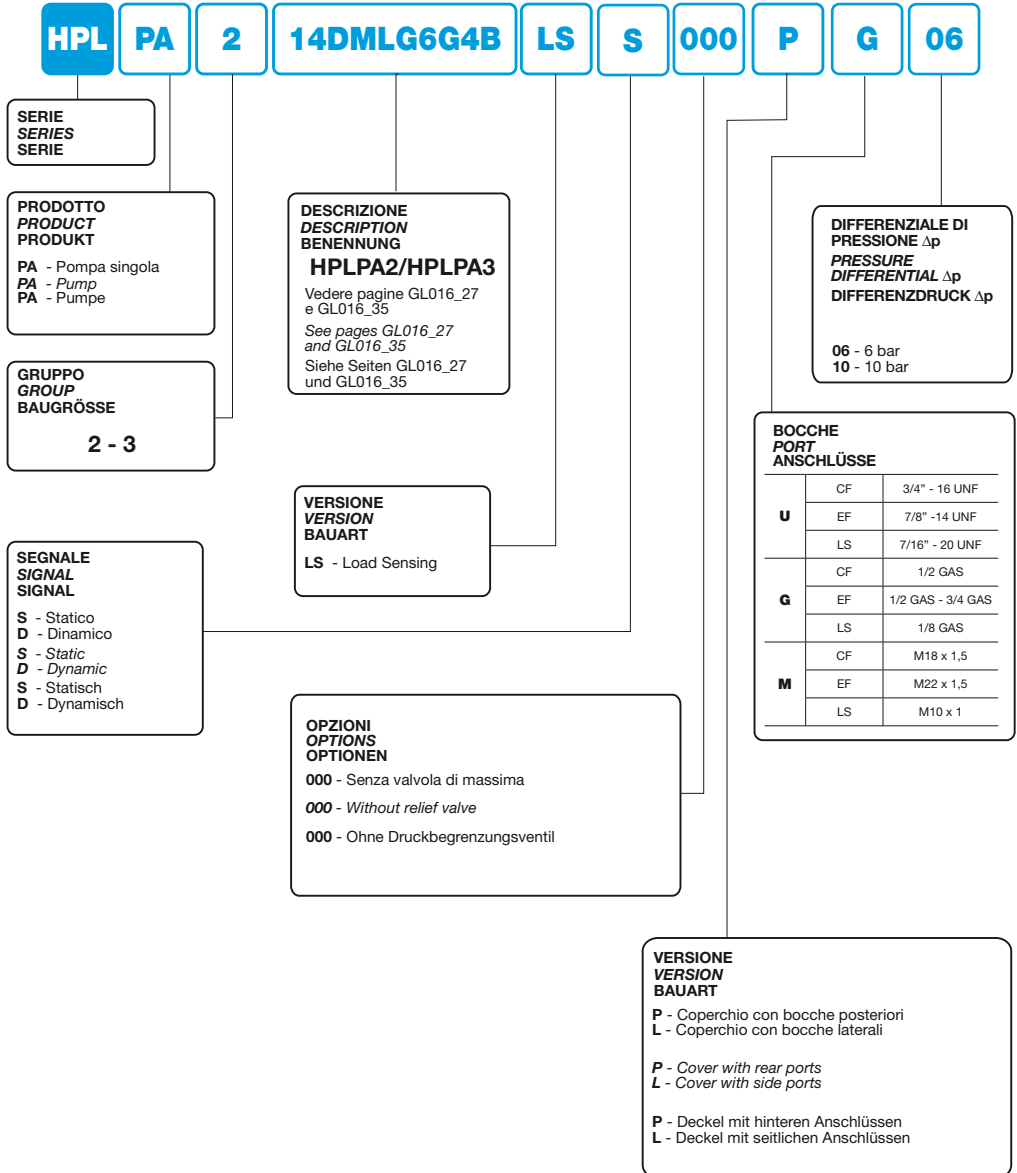

POMPE HIGH-LOW HIGH-LOW PUMPS ZAHNRADPUMPE HIGH-LOW

La pompa ad ingranaggi con logica HIGH-LOW è una pompa tandem con stadi a cilindrata uguali o diverse ed un bloccetto valvolato per permettere l'esclusione della pompa posteriore. Questa pompa viene utilizzata quando il motore elettrico o termico ha potenza limitata.

PRINCIPIO DI FUNZIONAMENTO: quando è richiesta elevata portata e bassa pressione le due pompe funzionano contemporaneamente, quando è richiesta elevata pressione e bassa portata la pompa posteriore viene esclusa rimandando la propria portata in aspirazione con dissipazione di potenza pressoché nulla. Questo permette di sfruttare tutta la potenza erogata dal motore sulla prima pompa.

La taratura della valvola nella configurazione standard è di 40 bar.

The HIGH-LOW pump is a tandem pump with equal or dissimilar displacements and a section with valves to allow the unloading of the rear pump.

This pump is applied when the main electric or engine motor has limited power.

WORKING: when high flow and low pressure is required the flow of both sections is combined at the outlet port, but when high pressure and low flow is required the rear pump is unloaded into the inlet port with negligible adsorbed power.

This enables the use of all the power supplied by the motor to the first pump. The valve setting in the standard version is 40 bar.

Die Zahnradpumpe mit HIGH-LOW-Logik ist eine Tandempumpe mit 2 gleichen oder unterschiedlichen Fördervolumina und einem integrierten Ventilblock, um die hintere Pumpe abzuschalten.

Diese Lösung wird verwendet, wenn der antreibende Elektro- oder Verbrennungsmotor eine begrenzte Leistung hat.

FUNKTIONSPRINZIP: Wenn besonders große Fördermengen bei niedrigem Druck benötigt werden, arbeiten beide Pumpen gleichzeitig. Bei hohem Druckbedarf und niedriger Fördermenge wird die hintere Pumpe abgeschaltet, indem deren Fördermenge in die Ansaugung der ersten Pumpe geleitet wird. Der Leistungsverlust ist dabei vernachlässigbar.

Auf diese Weise kommt die gesamte verfügbare Motorleistung der ersten Pumpe zugute. Standardmäßig ist das Ventil auf 40 bar eingestellt.

HPLPH1

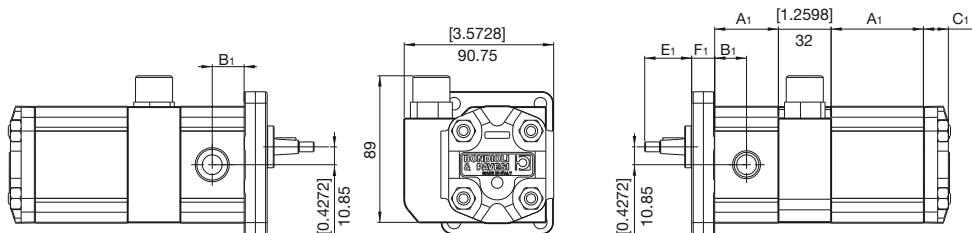

HPLPH2

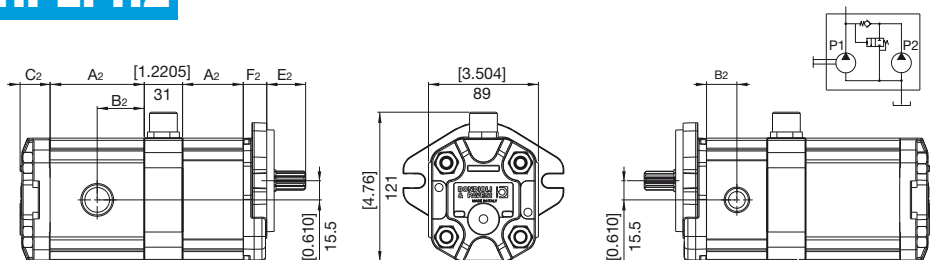



ISTRUZIONI PER L'ORDINAZIONE
ORDERING INSTRUCTIONS
BESTELLANLEITUNG

1° STADIO - STAGE - STUFE
(Descrizione - Description - Benennung)

2° STADIO - STAGE - STUFE
(Descrizione - Description - Benennung)



SERIE
SERIES
SERIE

PRODOTTO
PRODUCT
PRODUKT
PH - Pompa HIGH-LOW

GRUPPO
GROUP
BAUGRÖSSE **1 - 2**

CILINDRATA
DISPLACEMENT
FÖRDERVOLUMEN

HPL..1	HPL..2
19 - 1,90	05 - 4,50
24 - 2,53	06 - 6,00
31 - 3,17	08 - 8,50
36 - 3,73	11 - 11,00
44 - 4,35	14 - 14,50
48 - 4,97	17 - 17,00
60 - 6,08	20 - 19,50
70 - 7,00	
80 - 7,87	

SENSO DI ROTAZIONE
ROTATION
DREHRICHTUNG
D - Oraria/destra
Clockwise
Rechtslauf

FLANGIA ANTERIORE
FRONT FLANGE
VORDERER FLANSCH

HPL..1
D - Europea D 25.4 - European standard - EU-Norm.D 25.4
E - Europea D 30 - European Ø 30 - EU-Norm.D 30
G - Tedesca con OR - German with OR - DIN-Norm.
(mit O.R. Dichtung)
J - SAE AA - SAE AA - SAE AA

HPL..2
L - Europea in ghisa - European cast iron - EU-Norm Guß
M - Europea - European - EU-Norm
N - Tedesca - German - DIN-Norm
O - Tedesca D 50 2 fori DX - German D 50 2 holes right
DIN-Norm D 50 2 Bohrungen rechts
P - Tedesca D 50 2 fori SX - German D 50 2 holes left
DIN-Norm D 50 2 Bohrungen links
Q - SAE A 2 fori in ghisa - SAE A 2 holes cast iron
SAE A 2 Bohrungen Guß
R - Tedesca D 52 - German D 52 - DIN-Norm D 52
S - SAE A 2 fori - SAE A 2 holes - SAE A 2 Bohrungen
T - SAE B 2 fori in ghisa - SAE B 2 holes cast iron - SAE B 2
Bohrungen Guß
U - Perkins - Perkins - Perkins
V - Tedesca in ghisa - German cast iron - Din gussversion

ESTREMITÀ D'ALBERO
SHAFT PROFIL
WELLENENDE
HPL..1

D - Conico (1:8)
E - Cilindrico europeo
F - Cilindrico SAE "AA"
G - Conico (1:5)
H - Scanalato 12x9
I - Scanalato SAE "AA"
J - Dente frontale sporgente
K - Dente frontale
T - Conico high torque (1:8)

D - Tapered (1:8)
E - European parallel shaft
F - SAE "AA" parallel shaft
G - Tapered (1:5)
H - Splined 12x9
I - SAE "AA" splined
J - Front tooth
K - Tang drive
T - Tapered high torque (1:8)

D - Kegel (1:8)
E - cilindrisch (E-norm)
F - zylindrisch SAE "AA"
G - Kegel (1:5)
H - Keilwelle 12x9
I - Keilwelle SAE "AA"
J - Vorstehendes Kreuzprofil
K - Kreuzprofil
T - verstärkter Kegel (1:8)

HPL..2

L - Conico (1:8)
M - Conico (1:5)
N - Cilindrico D15 europeo
P - Cilindrico SAE "A"
U - Scanalato DIN 5482
V - Scanalato SAE "A" 9T
X - Scanalato SAE "A" 11T
Y - Scanalato SAE "B" 13T
Z - Dente frontale

L - Tapered (1:8)
M - Tapered (1:5)
N - D15 European parallel shaft
P - SAE "A" parallel shaft
U - DIN 5482 splined
V - SAE "A" 9T splined
X - SAE "A" 11T splined
Y - SAE "B" 13T splined
Z - Tang drive

L - Kegel (1:8)
M - Kegel (1:5)
N - zylindrisch (E-norm)
P - zylindrisch SAE "A"
U - Keilwelle DIN 5482
V - Keilwelle SAE "A" 9T
X - Keilwelle SAE "A" 11T
Y - Keilwelle SAE "B" 13T
Z - Kreuzprofil

SET VALVOLE
VALVE SETTING
VENTILEINSTELLUNG
(bar)

CILINDRATA
DISPLACEMENT
FÖRDERVOLUMEN

GRUPPO
GROUP
BAUGRÖSSE

GUARNIZIONI
SEALS
DICHTUNGEN
B - NBR
V - Viton

BOCCHE STD
STANDARD PORT - STANDARD ANSCHLÜSSE
HPL..1

CILINDRATA
DISPLACEMENT - FÖRDERVOLUMEN

1,9.....4,8	6.....8
Pompe - Pumps - Pumpen IN/OUT	Pompe - Pumps - Pumpen IN/OUT
E3 E3	E3 E3
G4 G3	G4 G4
X3 X3	X3 X3
M4 M2	M4 M2
U4 U3	U4 U4
G4 H1	G4 H1

HPL..2

CILINDRATA
DISPLACEMENT - FÖRDERVOLUMEN

5.....8	11	14.....20
Pompe - Pumps - Pumpen IN/OUT		Pompe - Pumps - Pumpen IN/OUT
E3 E3		E5 E3
G4 G4		G6 G4
X5 X4	X6 X4	X6 X4
U6 U5		U6 U5

**SUPPORTI
SPINDLES
VORSATZLAGER**

Per l'utilizzo delle pompe e dei motori in presenza di carichi assiali e/o radiali (trascinamento per mezzo di cinghie o catene e ruote dentate a ingranaggi dritti o elicoidali).

In funzione dell'entità dei carichi esterni sono disponibili diversi tipi di supporti. I diagrammi sottorportati guidano nella appropriata scelta del supporto. Fornibile separatamente (Cod. HPL5...) o montati sulla Pompa/Motore.

Bearings are suited for using pumps and motors in event of axial and/or radial loads (driving is carried out by means of belts or chains and sprocket wheels with straight-tooth/spiral gear).

Different types of supports are available based on the different types of external load. Refer to the following diagrams to select the proper type of support. Available separately (Cod. HPL5...) or mounted on the units.

Vorsatzlager werden verwendet, wenn auf die Pumpen/Motoren Axial- und/oder Radiallasten einwirken. Dabei erfolgt die Kraftübertragung über Riemen- oder Kettenantriebe mit geraden oder schräggestellten Zahnradern.

Je nach Ausmaß der externen Lasten sind verschiedene Lagertypen verfügbar. Die untenstehenden Diagramme dienen als Leitfaden für die richtige Auswahl des Lagers.

HPL...1

HPL5921C1R

HPL5921C2R

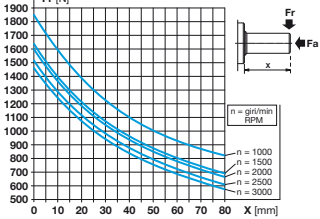
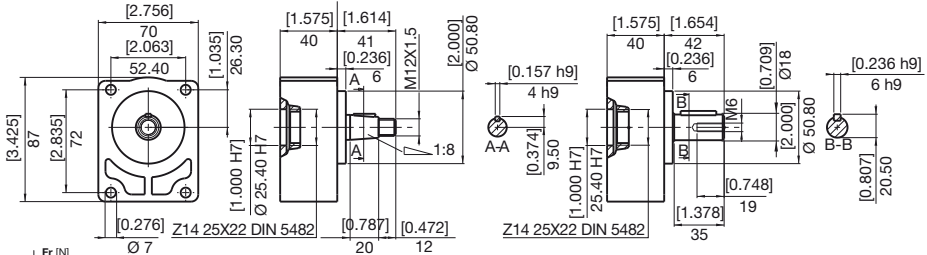

CARATTERISTICHE FEATURES EIGENSCHAFTEN							
CARICO RADIALE MINIMO* MINIMUM RADIAL LOAD* MIN. RADIAL-BELASTUNG*	CARICO RADIALE* RADIAL LOAD* RADIAL-BELASTUNG*	CARICO ASSIALE* AXIAL LOAD* AXIAL-BELASTUNG*	VELOCITÀ ROTAZIONE MAX MAX ROTATION SPEED MAX ROTATIONS-GESCHWINDIGKEIT	DURATA* DURATION* DAUER*	TEMPERATURA MAX DI LAVORO MAX OPERATING TEMPERATURE MAX. BETRIEBS-TEMPERATUR	QUANTITÀ GRASSO AMOUNT OF GREASE SCHMIERFETT MENGE	TIPO DI GRASSO TYPE OF GREASE SCHMIERFETT TYP
Fr = 130 N	Vedi grafico See chart siehe Grafik	Fa ≤ Fr • 0,8	4000 RPM	3500 h	70 °C	10 ÷ 12 gr	DIN 51818 NLGI classe 2

*Valori indicativi, calcolati secondo ISO 281. Per ulteriori informazioni rivolgersi al nostro ufficio tecnico
*Indicative values calculated in accordance with ISO 281. Contact our technical department for further information
* Richtwerte, gemäß ISO 281 berechnet. Für weitere Informationen richten Sie sich bitte an unser technisches Büro

HPL...2

HPL5922B1R

HPL5922B3R

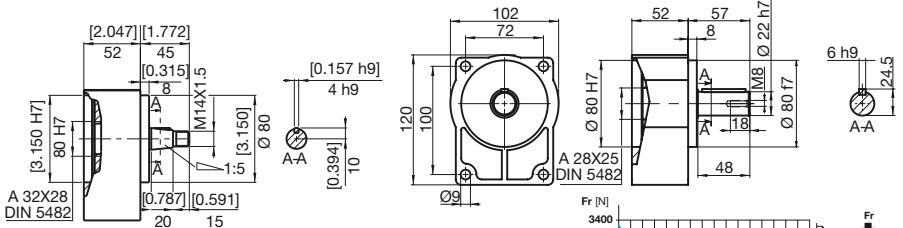

CARATTERISTICHE FEATURES EIGENSCHAFTEN							
CARICO RADIALE MINIMO* MINIMUM RADIAL LOAD* MIN. RADIAL-BELASTUNG*	CARICO RADIALE* RADIAL LOAD* RADIAL-BELASTUNG*	CARICO ASSIALE* AXIAL LOAD* AXIAL-BELASTUNG*	VELOCITÀ ROTAZIONE MAX MAX ROTATION SPEED MAX ROTATIONS-GESCHWINDIGKEIT	DURATA* DURATION* DAUER*	TEMPERATURA MAX DI LAVORO MAX OPERATING TEMPERATURE MAX. BETRIEBS-TEMPERATUR	QUANTITÀ GRASSO AMOUNT OF GREASE SCHMIERFETT MENGE	TIPO DI GRASSO TYPE OF GREASE SCHMIERFETT TYP
Fr = 277 N	Vedi grafico See chart siehe Grafik	Fa ≤ Fr • 0,8	3500 RPM	3500 h	70 °C	21 ÷ 27 gr	DIN 51818 NLGI classe 2

*Valori indicativi, calcolati secondo ISO 281. Per ulteriori informazioni rivolgersi al nostro ufficio tecnico
*Indicative values calculated in accordance with ISO 281. Contact our technical department for further information
* Richtwerte, gemäß ISO 281 berechnet. Für weitere Informationen richten Sie sich bitte an unser technisches Büro



HPL...2

HPL5922C3R

HPL5922C4R

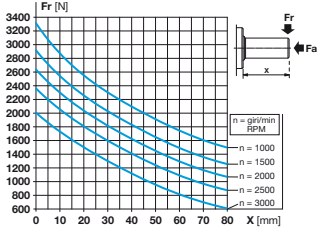
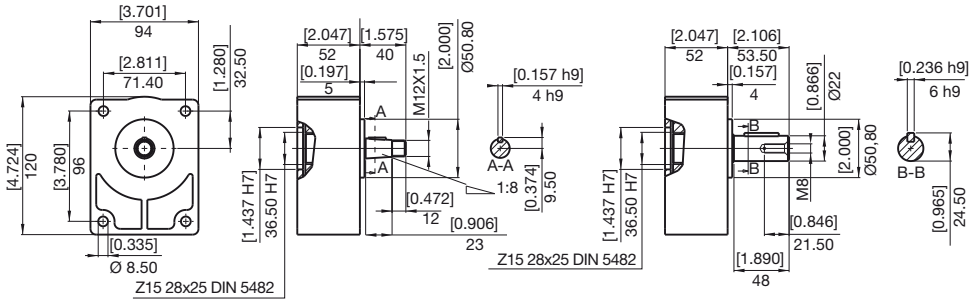

CARATTERISTICHE FEATURES EIGENSCHAFTEN

CARICO RADIALE MINIMO* MINIMUM RADIAL LOAD* MIN. RADIAL-BELASTUNG*	CARICO RADIALE* RADIAL LOAD* RADIAL-BELASTUNG*	CARICO ASSIALE* AXIAL LOAD* AXIAL-BELASTUNG*	VELOCITÀ ROTAZIONE MAX MAX ROTATION SPEED MAX. ROTATIONS-GESCHWINDIGKEIT	DURATA* DURATION* DAUER*	TEMPERATURA MAX DI LAVORO MAX OPERATING TEMPERATURE MAX. BETRIEBS-TEMPERATUR	QUANTITÀ GRASSO AMOUNT OF GREASE SCHMIERFETT MENGE	TIPO DI GRASSO TYPE OF GREASE SCHMIERFETT TYP
Fr = 277 N	Vedi grafico See chart siehe Grafik	Fa ≤ Fr • 0,8	3500 RPM	3500 h	70 °C	24 + 31,5 gr	DIN 51818 NLGI classe 2

*Valori indicativi, calcolati secondo ISO 281. Per ulteriori informazioni rivolgersi al nostro ufficio tecnico
*Indicative values calculated in accordance with ISO 281. Contact our technical department for further information
* Richtwerte, gemäß ISO 281 berechnet. Für weitere Informationen richten Sie sich bitte an unser technisches Büro

HPL...2

HPL5922C5R

HPL5922C6R

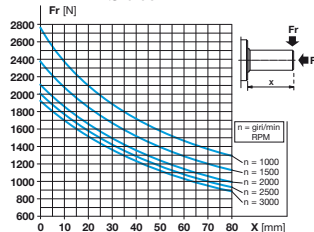
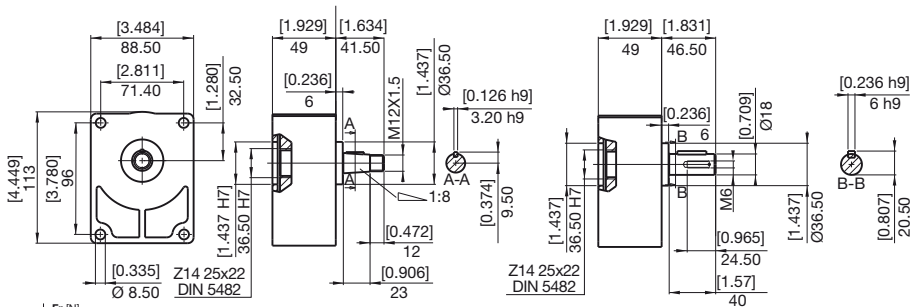

CARATTERISTICHE FEATURES EIGENSCHAFTEN

CARICO RADIALE MINIMO* MINIMUM RADIAL LOAD* MIN. RADIAL-BELASTUNG*	CARICO RADIALE* RADIAL LOAD* RADIAL-BELASTUNG*	CARICO ASSIALE* AXIAL LOAD* AXIAL-BELASTUNG*	VELOCITÀ ROTAZIONE MAX MAX ROTATION SPEED MAX. ROTATIONS-GESCHWINDIGKEIT	DURATA* DURATION* DAUER*	TEMPERATURA MAX DI LAVORO MAX OPERATING TEMPERATURE MAX. BETRIEBS-TEMPERATUR	QUANTITÀ GRASSO AMOUNT OF GREASE SCHMIERFETT MENGE	TIPO DI GRASSO TYPE OF GREASE SCHMIERFETT TYP
Fr = 155 N	Vedi grafico See chart siehe Grafik	Fa ≤ Fr • 0,8	4000 RPM	3500 h	70 °C	16,5 + 20,5 gr	DIN 51818 NLGI classe 2

*Valori indicativi, calcolati secondo ISO 281. Per ulteriori informazioni rivolgersi al nostro ufficio tecnico
*Indicative values calculated in accordance with ISO 281. Contact our technical department for further information
* Richtwerte, gemäß ISO 281 berechnet. Für weitere Informationen richten Sie sich bitte an unser technisches Büro

HPL...3

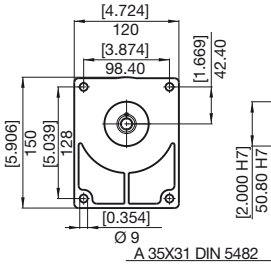

A 35X31 DIN 5482

HPL5923C7R

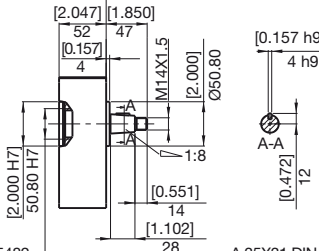

A 35X31 DIN 5482

HPL5923C8R

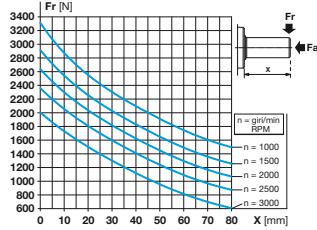
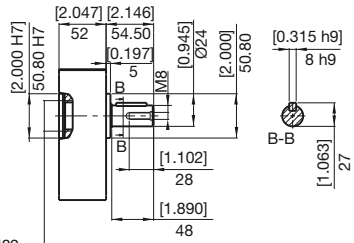

**CARATTERISTICHE
FEATURES
EIGENSCHAFTEN**

CARICO RADIALE MINIMO* MINIMUM RADIAL LOAD* MIN. RADIAL-BELASTUNG*	CARICO RADIALE* RADIAL LOAD* RADIAL-BELASTUNG*	CARICO ASSIALE* AXIAL LOAD* AXIAL-BELASTUNG*	VELOCITÀ ROTAZIONE MAX MAX ROTATION SPEED MAX. ROTATIONS-GESCHWINDIGKEIT	DURATA* DURATION* DAUER*	TEMPERATURA MAX DI LAVORO MAX OPERATING TEMPERATURE MAX. BETRIEBS-TEMPERATUR	QUANTITÀ GRASSO AMOUNT OF GREASE SCHMIERFETT MENGE	TIPO DI GRASSO TYPE OF GREASE SCHMIERFETT TYP
Fr = 277 N	Vedi grafico See chart siehe Grafik	Fa ≤ Fr • 0,8	3500 RPM	3500 h	70 °C	19 ± 23,5 gr	DIN 51818 NLGI classe 2

*Valori indicativi, calcolati secondo ISO 281. Per ulteriori informazioni rivolgersi al nostro ufficio tecnico
*Indicative values calculated in accordance with ISO 281. Contact our technical department for further information
* Richtwerte, gemäß ISO 281 berechnet. Für weitere Informationen richten Sie sich bitte an unser technisches Büro

HPL...4

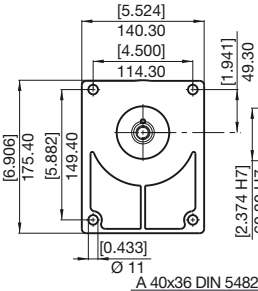

A 40x36 DIN 5482

HPL5924C9R

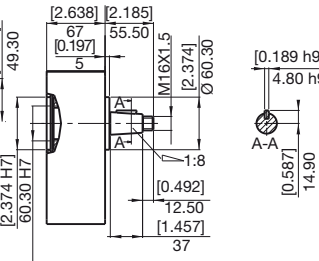

A 40x36 DIN 5482

HPL5924C0R

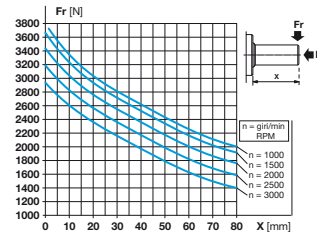
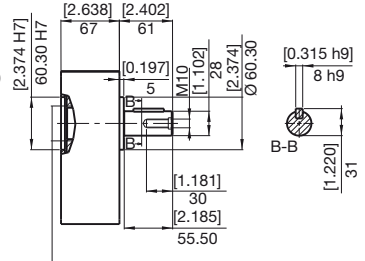

**CARATTERISTICHE
FEATURES
EIGENSCHAFTEN**

CARICO RADIALE MINIMO* MINIMUM RADIAL LOAD* MIN. RADIAL-BELASTUNG*	CARICO RADIALE* RADIAL LOAD* RADIAL-BELASTUNG*	CARICO ASSIALE* AXIAL LOAD* AXIAL-BELASTUNG*	VELOCITÀ ROTAZIONE MAX MAX ROTATION SPEED MAX. ROTATIONS-GESCHWINDIGKEIT	DURATA* DURATION* DAUER*	TEMPERATURA MAX DI LAVORO MAX OPERATING TEMPERATURE MAX. BETRIEBS-TEMPERATUR	QUANTITÀ GRASSO AMOUNT OF GREASE SCHMIERFETT MENGE	TIPO DI GRASSO TYPE OF GREASE SCHMIERFETT TYP
Fr = 476 N	Vedi grafico See chart siehe Grafik	Fa ≤ Fr • 0,8	3500 RPM	3500 h	70 °C	24 ± 29 gr	DIN 51818 NLGI classe 2

*Valori indicativi, calcolati secondo ISO 281. Per ulteriori informazioni rivolgersi al nostro ufficio tecnico
*Indicative values calculated in accordance with ISO 281. Contact our technical department for further information
* Richtwerte, gemäß ISO 281 berechnet. Für weitere Informationen richten Sie sich bitte an unser technisches Büro

14

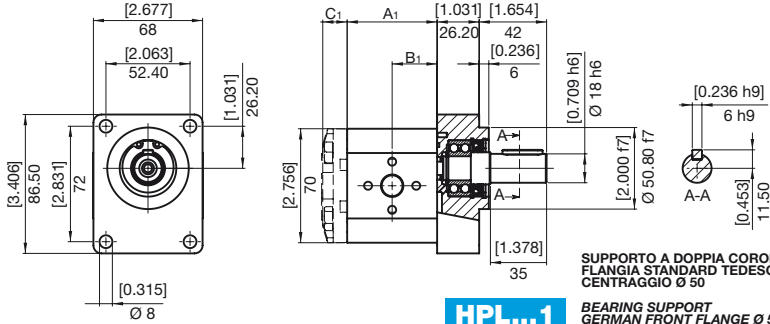

**ESTREMITA' D'ALBERO: CILINDRICO
SHAFT AVAILABLE: PARALLEL VERSION
LIEFERBARE WELLENENDEN: ZYLINDRISCH**

HPL...1

**SUPPORTO A DOPPIA CORONA DI SFERE
FLANGIA STANDARD TEDESCA
CENTRAGGIO Ø 50**

**BEARING SUPPORT
GERMAN FRONT FLANGE Ø 50**

**VORSATZLAGER MIT KUGELLAGER
DIN-NORM Ø 50**

11

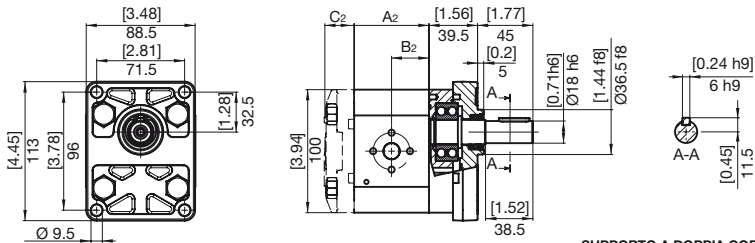

**ESTREMITA' D'ALBERO: CILINDRICO
SHAFT AVAILABLE: PARALLEL VERSION
LIEFERBARE WELLENENDEN: ZYLINDRISCH**

HPL...2

**SUPPORTO A DOPPIA CORONA DI SFERE
FLANGIA STANDARD EUROPEA
CENTRAGGIO Ø 36,50**

**BEARING SUPPORT
EUROPEAN FRONT FLANGE Ø 36,50**

**VORSATZLAGER MIT KUGELLAGER
EU-NORM Ø 36,50**

13

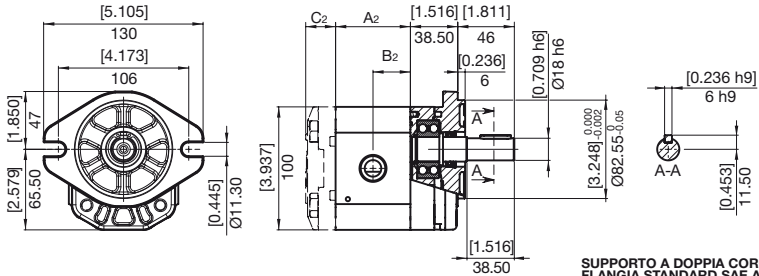

**ESTREMITA' D'ALBERO: CILINDRICO
SHAFT AVAILABLE: PARALLEL VERSION
LIEFERBARE WELLENENDEN: ZYLINDRISCH**

HPL...2

**SUPPORTO A DOPPIA CORONA DI SFERE
FLANGIA STANDARD SAE A
CENTRAGGIO Ø 82,50**

**BEARING SUPPORT
SAE A FRONT FLANGE Ø 82,50**

**VORSATZLAGER MIT KUGELLAGER
SAE A Ø 82,50**

**SUPPORTI INTEGRATI *
INTEGRATED SUPPORT *
INTEGRIERTES LAGER ***

17

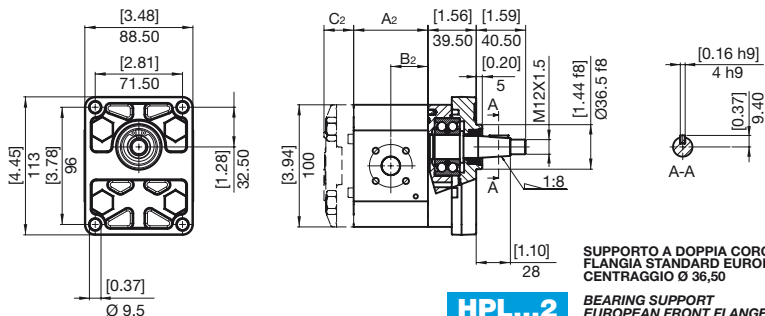

ESTREMITA' D'ALBERO: CONICO (1:8)
SHAFT AVAILABLE: TAPERED VERSION (1:8)
LIEFERBARE WELLENENDEN: KEGEL (1:8)

HPL...2

SUPPORTO A DOPPIA CORONA DI SFERE
FLANGIA STANDARD EUROPEA
CENTRAGGIO Ø 36,50

BEARING SUPPORT
EUROPEAN FRONT FLANGE Ø 36,50

VORSATZLAGER MIT KUGELLAGER
EU-NORM Ø 36,50

12

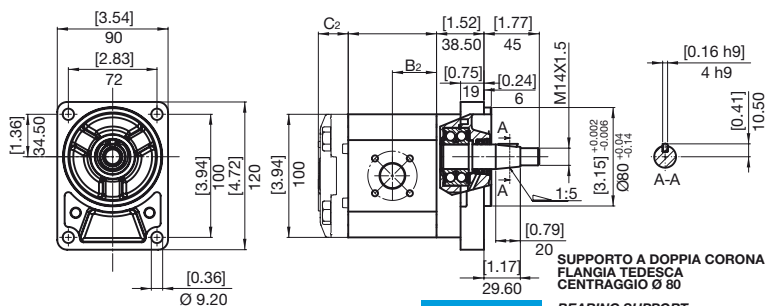

ESTREMITA' D'ALBERO: CONICO (1:5)
SHAFT AVAILABLE: TAPERED VERSION (1:5)
LIEFERBARE WELLENENDEN: KEGEL (1:5)

HPL...2

SUPPORTO A DOPPIA CORONA DI SFERE
FLANGIA TEDESCA
CENTRAGGIO Ø 80

BEARING SUPPORT
GERMAN FRONT FLANGE Ø 80

VORSATZLAGER MIT KUGELLAGER
DIN-NORM Ø 80

16

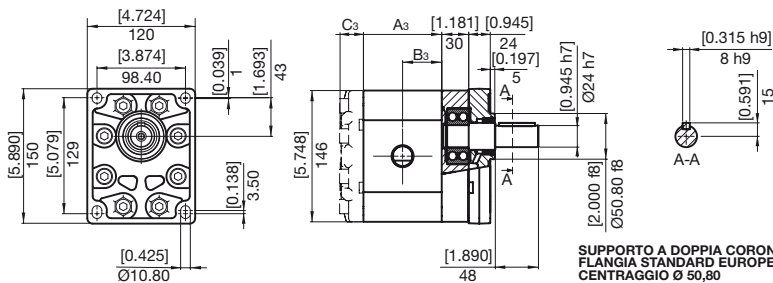

ESTREMITA' D'ALBERO: CILINDRICO
SHAFT AVAILABLE: PARALLEL VERSION
LIEFERBARE WELLENENDEN: ZYLINDRISCH

HPL...3

SUPPORTO A DOPPIA CORONA DI SFERE
FLANGIA STANDARD EUROPEA
CENTRAGGIO Ø 50,80

BEARING SUPPORT
EUROPEAN FRONT FLANGE Ø 50,80

VORSATZLAGER MIT KUGELLAGER
EU-NORM Ø 50,80

**SUPPORTI INTEGRATI *
INTEGRATED SUPPORT *
INTEGRIERTES LAGER ***

IB

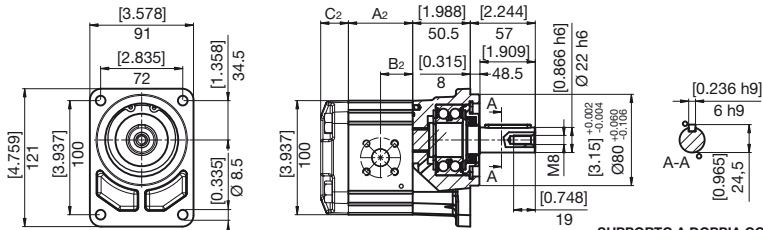

ESTREMITA' D'ALBERO: CILINDRICO
SHAFT AVAILABLE: PARALLEL VERSION
LIEFERBARE WELLENENDEN: ZYLINDRISCH

HPL...2

**SUPPORTO A DOPPIA CORONA DI SFERE
FLANGIA TEDESCA
CENTRAGGIO Ø 80**

**BEARING SUPPORT
GERMAN FRONT FLANGE Ø 80**

**VORSATZLAGER MIT KUGELLAGER
DIN-NORM Ø 80**

IC

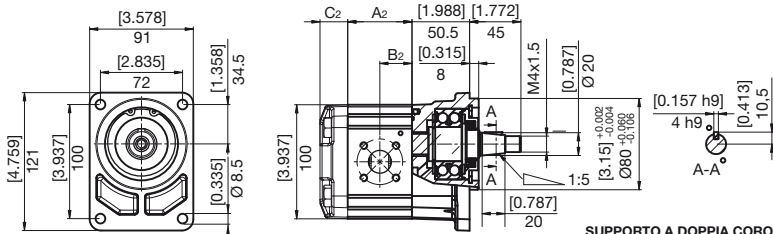

ESTREMITA' D'ALBERO: CONICO (1:5)
SHAFT AVAILABLE: TAPERED VERSION (1:5)
LIEFERBARE WELLENENDEN: KEGEL (1:5)

HPL...2

**SUPPORTO A DOPPIA CORONA DI SFERE
FLANGIA TEDESCA
CENTRAGGIO Ø 80**

**BEARING SUPPORT
GERMAN FRONT FLANGE Ø 80**

**VORSATZLAGER MIT KUGELLAGER
DIN-NORM Ø 80**

POMPE E MOTORI COMPLETI DI SUPPORTO
PUMP OR MOTOR WITH BEARING SUPPORT
PUMPEN UND MOTOREN MIT VORSATZLAGER

HPL

PA

2

11

D

C5

SERIE
SERIES
SERIE

PRODOTTO
PRODUCT
PRODUKT

MA - Motore
PA - Pompa singola
PB - Pompa doppia
PC - Pompa tripla
MA - Motor
PA - Pump
PB - Double Pump
PC - Triple Pump
MA - Motor
PA - Pump
PB - Doppelpumpe
PC - Dreifachpumpe

GRUPPO
GROUP
BAUGRÖSSE

1 - 2 - 3 - 4

CILINDRATA
DISPLACEMENT
FÖRDERVOLUMEN

HPL..1	HPL..2	HPL..3	HPL..4
14 - 1,37	05 -4,50	22 -21,50	41 -41,50
19 - 1,90	06 -6,00	26 -26,00	51 -50,50
24 - 2,53	08 -8,50	31 -30,50	61 -61,00
31 - 3,17	11 -11,00	36 -36,00	73 -72,00
36 - 3,73	14 -14,50	41 -41,50	90 -88,00
44 - 4,35	17 -17,00	47 -46,50	
48 - 4,97	20 -19,50	51 -50,50	
60 - 6,08	26 -26,00	56 -55,50	
70 - 7,00	34 -34,00	61 -61,00	
80 - 7,87	40 -40,50	73 -72,00	
		90 -88,00	

SENSO DI ROTAZIONE **ROTATION** **DREHRICHTUNG**

S - Antioraria/sinistra
D - Oraria/destra
H - Bidirezionale drenaggio interno
B - Bidirezionale drenaggio esterno posteriore

S - Counterclockwise
D - Clockwise
H - Reversible ind drain
B - Reversible rear. drain. pont

S - Linkslauf
D - Rechtslauf
H - reversibel, Lecköl intern, Anschluß seitlich
B - reversibel, Lecköl extern, Anschluß hinten

TIPO DI SUPPORTO
SPINDLE TYPE
VORSATZLAGER

HPL..1

C1 - Conico (1:8) Ø 50,8
C2 - Cilindrico Ø 50,8
I4 - Integrato Cilindrico Ø 50,8
C1 - Tapered (1:8) Ø 50,8
C2 - Parallel shaft Ø 50,8
I4 - Integrated Parallel shaft Ø 50,8

C1 - Kegel (1:8) Ø 50,8
C2 - Zylindrisch Ø 50,8
I4 - integriertes Lager
 Zylindrisch Ø 50,8

HPL..2

C3 - Conico (1:8) Ø 50,8
C4 - Cilindrico Ø 50,8
C5 - Conico (1:8) Ø 36,5
C6 - Cilindrico Ø 36,5
I1 - Integrato cilindrico Ø 36,5
I2 - Integrato conico (1:5) Ø 80
I3 - Integrato cilindrico Ø 82,5 SAE
I7 - Integrato conico (1:8) Ø 36,5
IB - Cilindrico Ø 80
IC - Conico (1:5) Ø 80
B1 - Conico (1:5) Ø 80
B3 - Cilindrico Ø 80

C3 - Tapered (1:8) Ø 50,8
C4 - Parallel shaft Ø 50,8
C5 - Tapered (1:8) Ø 36,5
C6 - Parallel shaft Ø 36,5
I1 - Integrated parallel shaft Ø 36,5
I2 - Integrated tapered (1:5) Ø 80
I3 - Integrated parallel shaft Ø 82,5 SAE
I7 - Integrated tapered (1:8) Ø 36,5
IB - Parallel shaft Ø 80
IC - Tapered (1:5) Ø 80
B1 - Tapered (1:5) Ø 80
B3 - Parallel shaft Ø 80

C3 - Kegel (1:8) Ø 50,8
C4 - Zylindrisch Ø 50,8
C5 - Kegel (1:8) Ø 36,5
C6 - Zylindrisch Ø 36,5
I1 - integriertes Lager
 Zylindrisch Ø 36,5
I2 - Kegel Zylindrisch (1:5) Ø 80
I3 - integriertes Lager
 Zylindrisch Ø 82,5 SAE
I7 - Kegel Zylindrisch (1:8) Ø 36,5
IB - Zylindrisch Ø 80
IC - Kegel (1:5) Ø 80
B1 - Kegel (1:5) Ø 80
B3 - Zylindrisch Ø 80

HPL..3

C7 - Conico (1:8) Ø 50,8
C8 - Cilindrico Ø 50,8
I6 - Integrato cilindrico Ø 50,8
C7 - Tapered (1:8) Ø 50,8
C8 - Parallel shaft Ø 50,8
I6 - Integrated Parallel shaft Ø 50,8
C7 - Kegel (1:8) Ø 50,8
C8 - zylindrisch Ø 50,8
I6 - integriertes Lager
 Zylindrisch Ø 50,8

HPL..4

C9 - Conico (1:8) Ø 60,3
C0 - Cilindrico Ø 60,3
C9 - Tapered (1:8) Ø 60,3
C0 - Parallel shaft Ø 60,3
C9 - Kegel (1:8) Ø 60,3
C0 - zylindrisch Ø 60,3



ISTRUZIONI PER L'ORDINAZIONE
ORDERING INSTRUCTIONS
BESTELLANLEITUNG

G4 G4

B

ST

--

SET VALVOLE
VALVE SETTING
VENTILEINSTELLUNG
(bar)

COPERCHI
COVERS
DECKEL
ST - Standard
V. - Con valvole
(Vedi sez. valvole)
With valves
(See valves section)
Mit Ventilen
(siehe Abschnitt Ventile)
SG - Versione in ghisa.
Non disponibile per il Gruppo 1
Cast iron version
Not available for Group 1
Gussversion
Nicht vorhanden für Gruppe 1

BOCCHIE STD STANDARD PORT STANDARD ANSCHLÜSSE					
CILINDRATA		DISPLACEMENT		FÖRDER-/SCHLUCKVOLUMEN	
HPL...1					
1,4.....4,8		6.....8		1,4.....4,8	
Pompe - Pumps - Pumpen IN/OUT		Pompe - Pumps - Pumpen IN/OUT		Pompe - Pumps - Pumpen IN/OUT	
DRAIN		DRAIN		DRAIN	
E3 E3	E3 E3	M1	U3 U3	U4 U4	U2
G3 G3	G4 G4	G2	T3 T3	T4 T3	G2
X3 X3	X3 X3	M1	C3 C3	C4 C3	U2
M4 M2	M4 M2	M1			

MOTORI - MOTORS - MOTOREN OUT/IN
MOTORI BIDIR. IN=OUT - REVERS. MOTORS IN=OUT - BIDIREK.MOTOREN IN=OUT

HPL...2					
5.....8		11		14.....20	
Pompe - Pumps - Pumpen IN/OUT		Pompe - Pumps - Pumpen IN/OUT		Pompe - Pumps - Pumpen IN/OUT	
DRAIN		DRAIN		DRAIN	
E3 E3	E5 E3	E5 E5	E5 E5	M2	
G4 G4	G6 G4	G6 G6	G7 G6	G3	
X5 X4	X6 X4	X6 X5	X8 X6	M2	
U6 U5	U6 U5	U6 U5	U7 U6	U3	
N4 N4	N6 N4	N7 N6	N7 N6	M2	
C6 C5	C6 C5	C6 C5		U3	
T6 T4	T6 T4	T6 T4		G3	

MOTORI - MOTORS - MOTOREN OUT/IN
MOTORI BIDIR. IN=OUT - REVERS. MOTORS IN=OUT - BIDIREK.MOTOREN IN=OUT

HPL...3					
22.....31		36.....61		73.....90	
Pompe - Pumps - Pumpen IN/OUT		Pompe - Pumps - Pumpen IN/OUT		Pompe - Pumps - Pumpen IN/OUT	
DRAIN		DRAIN		DRAIN	
E5 E5	E7 E5	E8 E7	M3		
G6 G6	G7 G6	G8 G7	G3		
U7 U6	U8 U7	U8 U7	M3		
N7 N6	N7 N6	N8 N7	M3		
X8 X7	X8 X7	X8 X7	M3		

MOTORI - MOTORS - MOTOREN OUT/IN
MOTORI BIDIR. IN=OUT - REVERS. MOTORS IN=OUT - BIDIREK.MOTOREN IN=OUT

HPL...4					
41.....61		73.....90		DRAIN	
Pompe - Pumps - Pumpen IN/OUT		Pompe - Pumps - Pumpen IN/OUT		DRAIN	
E7 E7	E8 E7	G3			
G7 G7	G8 G8	G3			
X8 X7	X8 X7	G3			

MOTORI - MOTORS - MOTOREN OUT/IN
MOTORI BIDIR. IN=OUT - REVERS. MOTORS IN=OUT - BIDIREK.MOTOREN IN=OUT

GUARNIZIONI
SEALS
DICHTUNGEN

B - NBR
R - NBR alte pres. (picco 25 bar)
For high pres. (peak 25 bar)
Hochdruck (spitzen 25 bar)
V - Viton
W - Viton alte pres. (picco 25 bar)
For high pres. (peak 25 bar)
Hochdruck (spitzen 25 bar)

I divisori di flusso ad ingranaggi sono componenti idraulici non dissipativi, composti da più sezioni collegate tra loro, che suddividono la portata entrante Q_0 in parti uguali o proporzionali tra loro Q_n , permettendo di ottenere movimenti sincroni di più attuatori indipendentemente dal carico.

Gear flow dividers are non-dissipative hydraulic components consisting of multiple interconnected sections, which divide the inflow Q_0 into equal or mutually proportional parts Q_n , allowing for synchronised movement of multiple actuators independently of the load.

Die Mengenteiler mit Zahradbetrieb sind hydraulische Durchgangskomponenten, die aus mehreren miteinander verbundenen Stufen bestehen, die die eintretende Fördermenge Q_0 in gleiche oder untereinander proportionale Teile Q_n aufteilen und somit synchrone Bewegungen mehrerer Stellglieder unabhängig von der Last ermöglichen.

$$Q_0 = Q_1 + Q_2 + \dots + Q_n$$

$$p_0 Q_0 = p_1 Q_1 + p_2 Q_2 + \dots + p_n Q_n$$

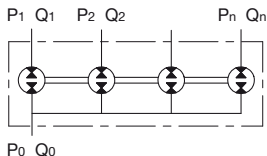

Dove: Q = portata [l/min]
 p = pressione [bar]

I divisori di flusso possono essere utilizzati anche come intensificatori di pressione per aumentare la pressione di lavoro di un impianto.

Where: Q = flow rate [l/min]
 p = pressure [bar]

Flow dividers can also be used as pressure intensifiers to increase the working pressure of a plant.

Wobei: Q = Fördermenge [l/min]
 p = Druck [bar]

Die Mengenteiler können auch als Druckverstärker eingesetzt werden, um den Arbeitsdruck einer Anlage zu erhöhen.

ISTRUZIONI GENERALI D'IMPIEGO E VERSIONI

I divisori di flusso della serie L sono prodotti nei gruppi 1, 2 e 3 in diverse configurazioni.

Per un dimensionamento di massima del divisore, occorre conoscere la portata in ingresso Q_0 [l/min] ed il numero delle sezioni n . Si determina così la cilindrata teorica V_t [cm³] con la formula:

$$V_t = \frac{0,5 \cdot Q_0}{n}$$

Si selezionerà poi la cilindrata più prossima dalla tabella dati tecnici.

La configurazione standard (Fig.1) prevede le porte d'ingresso e di uscita su ciascuna sezione del divisore, le bocche di ingresso ed uscita sono della stessa dimensione.

La configurazione ad entrata unica è suddivisa nella versione con ingresso laterale sul coperchio (Fig.2) o con ingresso sul corpo (Fig.3). Il numero delle porte di ingresso è funzione del numero degli stadi secondo la seguente relazione:

per $n < 4$ Numero ingressi $l = 1$
per $n > 4$ Numero ingressi $l = \text{INT}(\frac{n}{4} + 1)$

Es. Divisore a $n = 5$ stadi →
numero ingressi $l = \text{INT}(2.25) = 2$

Le porte di ingresso per $n > 4$ sono della stessa dimensione.

GENERAL INSTRUCTIONS FOR USE AND VERSIONS

L series flow dividers are produced in groups 1, 2 and 3 and in different configurations.

For maximum dimensioning of the divider, it is necessary to know the inlet flow rate Q_0 [l/min] and the number of sections n . In this way it is possible to determine the theoretical displacement V_t [cm³] using the formula:

$$V_t = \frac{0,5 \cdot Q_0}{n}$$

Then select the closest displacement from the technical data table.

The standard configuration (Fig.1) envisages inlet and outlet ports on each section of the divider; the inlet and outlet ports are the same size.

The single inlet configuration is divided into the version with lateral inlet on the cover (Fig.2) or with inlet on the body (Fig.3). The number of inlet ports depends on the number of stages according to the following relationship:

for $n < 4$ Number of inlets $l = 1$
for $n > 4$ Number of inlets $l = \text{INT}(\frac{n}{4} + 1)$

E.g. Divider with $n = 5$ stages →
number of inlets $l = \text{INT}(2.25) = 2$

The inlet ports for $n > 4$ are the same size.

ALLGEMEINE ANLEITUNGEN ZUR NUTZUNG UND VERSIONEN

Die Mengenteiler der Serie L werden in den Baugrößen 1, 2 und 3 in verschiedenen Konfigurationen hergestellt.

Zur Bestimmung der grundsätzlichen Abmessungen des Mengenteilers müssen die eintretende Fördermenge Q_0 [l/min] und die Anzahl der Stufen n bekannt sein. Auf diese Weise wird das theoretische Fördervolumen V_t [cm³] mit folgender Formel bestimmt:

$$V_t = \frac{0,5 \cdot Q_0}{n}$$

Anschließend wählt man den nächstliegenden Fördervolumenwert aus der Tabelle der technischen Daten aus.

Die Standardkonfiguration (Abb. 1) sieht die Ein- und Ausgangsöffnungen an jeder Stufe des Mengenteilers vor. Ein- und Ausgangsöffnungen weisen die gleichen Maße auf.

Die Konfiguration mit einzigem Eingang ist unterteilt in die Version mit seitlichem Eingang am Deckel (Abb. 2) oder mit Eingang am Gehäuse (Abb. 3). Die Anzahl der Eingangsanschlüsse hängt von der Anzahl der Stufen gemäß folgender Verhältnisgleichung ab:

für $n < 4$ Anzahl Eingangsanschlüsse $l = 1$
für $n > 4$ Anzahl Eingangsanschlüsse $l = \text{INT}(\frac{n}{4} + 1)$

Beispiel: Mengenteiler mit $n = 5$ Stufen →
Anzahl Eingangsanschlüsse $l = \text{INT}(2.25) = 2$

Die Eingangsanschlüsse für $n > 4$ weisen alle das gleiche Maß auf.

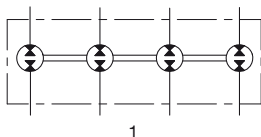

1

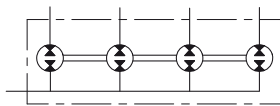

2

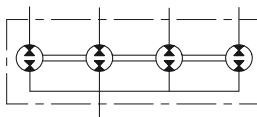

3

I divisori di flusso del gruppo 1 e 2 possono essere forniti con valvole di massima pressione per consentire il rifasamento degli attuatori al termine della corsa. Le valvole sono tarabili e posizionate su ciascuna sezione del divisore, mentre il drenaggio è esterno e comune per tutte le valvole.

La versione valvolata è disponibile nella configurazione standard (Fig.4) e con ingresso unico su coperchio (Fig.5) e corpo (Fig.6).

Group 1 and 2 flow dividers can be supplied with relief valves to enable the rephasing of the actuators at the end of the stroke. The valves can be calibrated and positioned on each section of the divider, whereas the drain is external and common to all valves.

The valved version is available in the standard configuration (Fig. 4) and with single inlet on the cover (Fig. 5) and body (Fig. 6).

Die Mengenteiler der Baugrößen 1 und 2 können mit Druckbegrenzungsventilen geliefert werden, um die Phasenregelung der Stellglieder am Ende des Hubs zu ermöglichen. Die Ventile sind einstellbar und in jeder Stufe des Mengenteilers positioniert, während der Leckölanschluss extern und gemeinsam für alle Ventile gelegt ist. Die mit Ventilen versehene Version ist in der Standardkonfiguration (Abb. 4) und mit einzigem Eingang am Deckel (Abb. 5) und Gehäuse (Abb. 6) verfügbar.

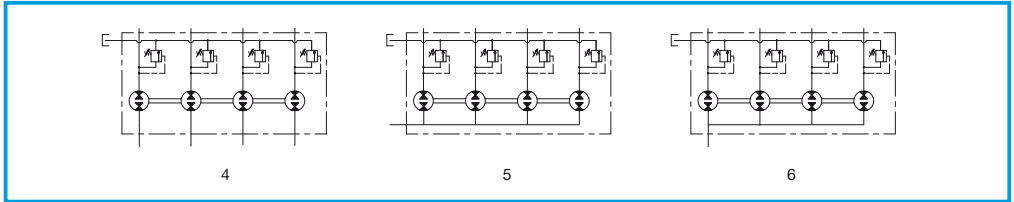

HPLDF.1

HPLDF.2

**DIVISORE A DUE STADI
ENTRATA UNICA CORPO**

**TWO-STAGE DIVIDER
SINGLE INLET BODY**

**2-STUFIGER MENGENTEILER
GEHÄUSE MIT
GEMEINSAMEM EINLASS**

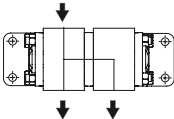

**DIVISORE DA DUE A QUATTRO
STADI ENTRATA UNICA COPERCHIO**

**TWO TO FOUR-STAGE
DIVIDER SINGLE INLET COVER**

**2- BIS 4-STUFIGER MENGENTEILER
GEHÄUSE MIT GEMEINSAMEM EINLASS**

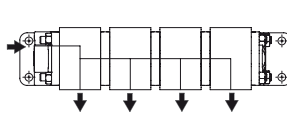

**DIVISORE A TRE E A QUATTRO
STADI ENTRATA UNICA CORPO**

**THREE AND FOUR-STAGE
DIVIDER SINGLE INLET BODY**

**3- UND 4-STUFIGER MENGENTEILER
GEHÄUSE MIT GEMEINSAMEM
EINLASS**

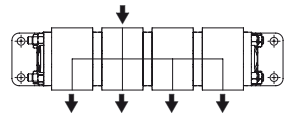

**DIVISORE DA CINQUE A SEI STADI
ENTRATA UNICA COPERCHIO**

**FIVE TO SIX-STAGE DIVIDER
SINGLE INLET COVER**

**5- BIS 6-STUFIGER MENGENTEILER
GEHÄUSE MIT GEMEINSAMEM EINLASS**

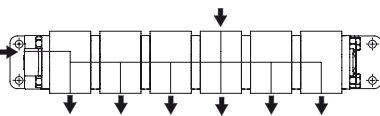

**DIVISORE A CINQUE E A SEI STADI
ENTRATA UNICA CORPO**

**FIVE AND SIX-STAGE
DIVIDER SINGLE INLET BODY**

**5- BIS 6-STUFIGER MENGENTEILER
GEHÄUSE MIT GEMEINSAMEM EINLASS**

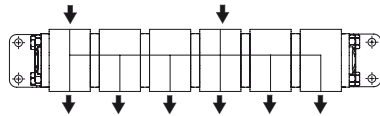

DIVISORI DI FLUSSO
FLOW DIVIDERS
MENGENTEILER

HPLDF.1

DIVISORE VALVOLATO A DUE STADI E.U. CORPO
TWO-STAGE VALVED DIVIDER S.I. BODY

2-STUFIGER STROMTEILER MIT VENTILEN UND GEMEINSAMEM EINLASS IM GEHÄUSE

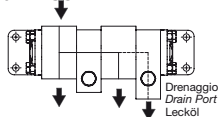

DIVISORE VALVOLATO DA DUE A QUATTRO STADI E.U. COPERCHIO
TWO TO FOUR-STAGE VALVED DIVIDER S.I. COVER

2- BIS 4-STUFIGER STROMTEILER MIT VENTILEN UND GEMEINSAMEM EINLASS IM DECKEL

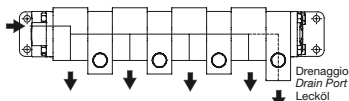

DIVISORE VALVOLATO A TRE E A QUATTRO STADI E.U. CORPO
THREE AND FOUR-STAGE VALVED DIVIDER S.I. BODY

2- BIS 4-STUFIGER STROMTEILER MIT VENTILEN UND GEMEINSAMEM EINLASS IM GEHÄUSE

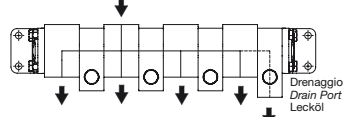

DIVISORE VALVOLATO A CINQUE E A SEI STADI E.U. COPERCHIO
FIVE AND SIX-STAGE VALVED DIVIDER S.I. COVER

5- UND 6-STUFIGER STROMTEILER MIT VENTILEN UND GEMEINSAMEM EINLASS IM DECKEL UND GEHÄUSE

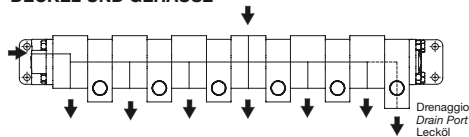

DIVISORE VALVOLATO A CINQUE E A SEI STADI E.U. CORPO
FIVE AND SIX-STAGE VALVED DIVIDER S.I. BODY

5- UND 6-STUFIGER STROMTEILER MIT VENTILEN UND GEMEINSAMEM EINLASS IM GEHÄUSE

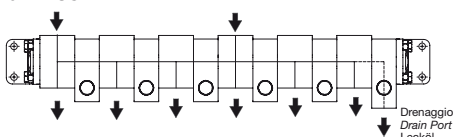

HPLDF.2

DIVISORE VALVOLATO A DUE STADI E.U. CORPO
TWO-STAGE VALVED DIVIDER S.I. BODY

2-STUFIGER STROMTEILER MIT VENTILEN UND GEMEINSAMEM EINLASS IM GEHÄUSE

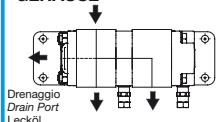

DIVISORE VALVOLATO DA DUE A QUATTRO STADI E.U. COPERCHIO
TWO TO FOUR-STAGE VALVED DIVIDER S.I. COVER

2- BIS 4-STUFIGER STROMTEILER MIT VENTILEN UND GEMEINSAMEM EINLASS IM DECKEL

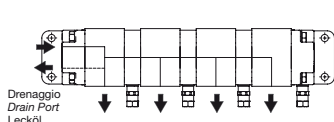

DIVISORE VALVOLATO A TRE E A QUATTRO STADI E.U. CORPO
THREE AND FOUR-STAGE VALVED DIVIDER S.I. BODY

3- UND 4-STUFIGER STROMTEILER MIT VENTILEN UND GEMEINSAMEM EINLASS IM GEHÄUSE

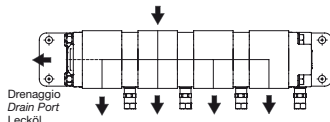

DIVISORE VALVOLATO DA CINQUE A SEI STADI E.U. COPERCHIO
FIVE AND SIX-STAGE VALVED DIVIDER S.I. COVER

6-STUFIGER STROMTEILER MIT VENTILEN UND GEMEINSAMEM EINLASS IM DECKEL UND GEHÄUSE

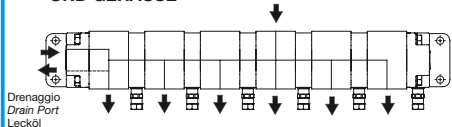

DIVISORE VALVOLATO A CINQUE E A SEI STADI E.U. CORPO
FIVE AND SIX-STAGE VALVED DIVIDER S.I. BODY

6-STUFIGER STROMTEILER MIT VENTILEN UND GEMEINSAMEM EINLASS IM GEHÄUSE

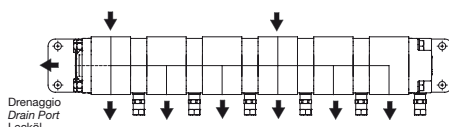



DIVISORI DI FLUSSO
FLOW DIVIDERS
MENGENTEILER

HPLDF..

PROGRAMMA DI PRODUZIONE
PRODUCTION RANGE
MENGENTEILER

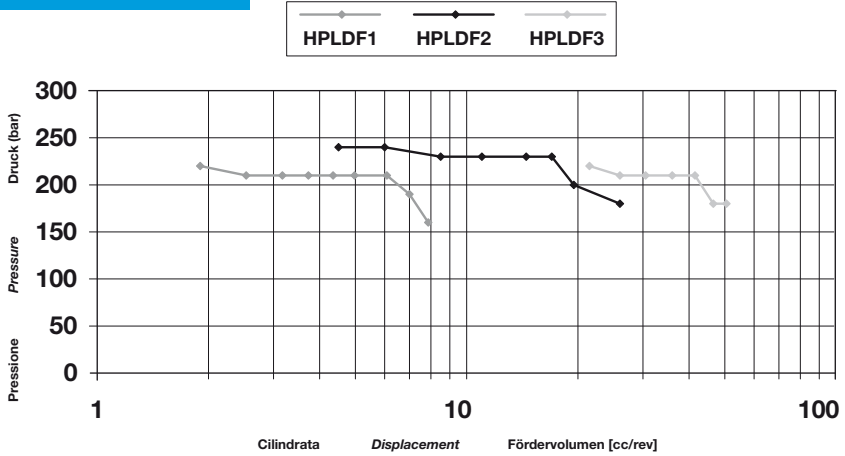

DATI TECNICI
TECHNICAL DATA
TECHNISCHE MERKMALE

GRUPPO GROUP BAUREIHE	TIPO TYPE TYP	CILINDRATA TEORICA NOMINAL DISPLACEMENT FÖRDERVOLUMEN (TM)		PRESSIONE PRESSURE DRUCK		INTERMITTENTE INTERMITTIERENDER		ΔP MAX TRA LE SEZIONI ΔP MAX OUTLET BETWEEN SECTIONS ΔP ZWISCHEN DEN STUFEN		VELOCITÀ DI ROTAZIONE SPEED DREHZAHL	
		cm ³	in ³	bar	psi	bar	psi	bar	psi	MIN min ⁻¹	MAX min ⁻¹
1	19	1,90	0,12	220	3191	260	3771	190	2756	700	4800
	24	2,53	0,15	210	3046	250	3626	180	2611		
	31	3,17	0,19	210	3046	250	3626	180	2611		
	36	3,73	0,23	210	3046	250	3626	180	2611		
	44	4,35	0,27	210	3046	250	3626	180	2611		
	48	4,97	0,30	210	3046	250	3626	180	2611		
	60	6,08	0,37	210	3046	250	3626	180	2611		
	70	7,00	0,43	190	2756	210	3046	160	2321		
80	7,87	0,48	160	2321	180	2611	130	1885	3600		
2	05	4,50	0,27	240	3481	260	3771	210	3046	700	4000
	06	6,00	0,37	240	3481	260	3771	210	3046		
	08	8,50	0,52	230	3336	250	3626	200	2901		
	11	11,00	0,67	230	3336	250	3626	200	2901		
	14	14,50	0,88	230	3336	250	3626	200	2901		
	17	17,00	1,04	230	3336	250	3626	200	2901		
	20	19,50	1,19	200	2901	220	3191	170	2466		
26	26,00	1,59	180	2611	190	2756	150	2176	3400		
3	22	21,50	1,31	220	3191	250	3626	190	2756	700	3500
	26	26,00	1,59	210	3046	250	3626	180	2611		
	31	30,50	1,86	210	3046	250	3626	180	2611		
	36	36,00	2,20	210	3046	250	3626	180	2611		
	41	41,50	2,53	210	3046	250	3626	180	2611		
	47	46,50	2,84	180	2611	210	3046	150	2176		
51	50,50	3,08	180	2611	210	3076	150	2176			

HPLDF.1 CONFIGURAZIONE STANDARD
 STANDARD CONFIGURATION
 STANDARDKONFIGURATION

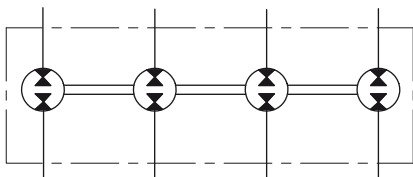
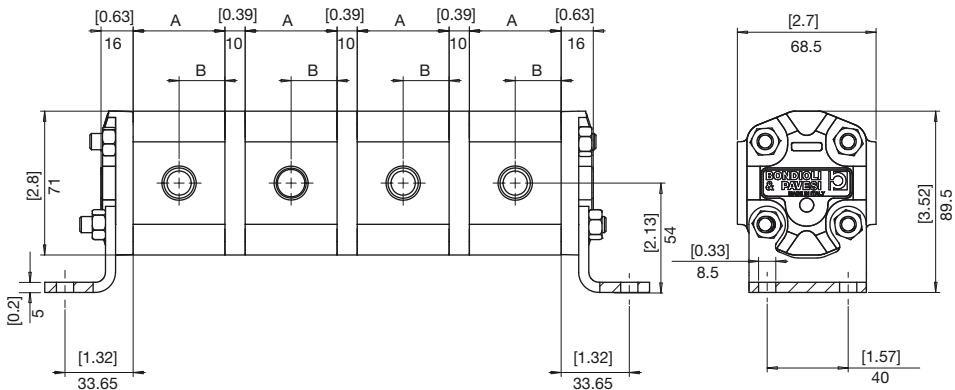

DIMENSIONI
SIZE
ABMESSUNGEN

GRUPPO GROUP BAUREIHE	TIPO TYPE TYP	A		B	
		mm	in	mm	in
1	19	38,7	1,524	19,4	0,762
	24	38,7	1,524	19,4	0,762
	31	38,7	1,524	19,4	0,762
	36	45,35	1,785	22,7	0,893
	44	45,35	1,785	22,7	0,893
	48	45,35	1,785	22,7	0,893
	60	56,05	2,207	28,0	1,103
	70	56,05	2,207	28,0	1,103
80	56,05	2,207	28,0	1,103	

HPLDF.1

CONFIGURAZIONE ENTRATA UNICA
SINGLE INLET CONFIGURATION
KONFIGURATION MIT EINZIGEM EINGANG

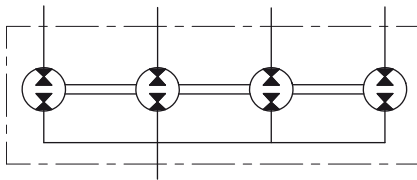
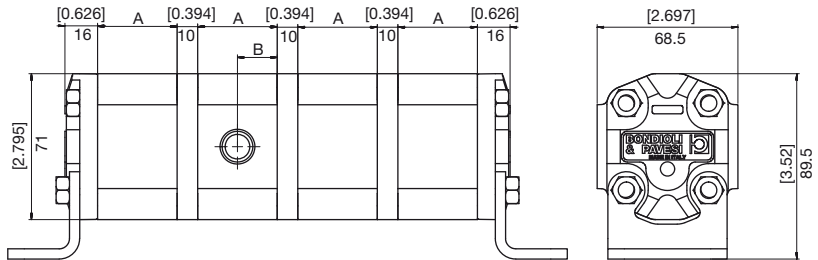

DIMENSIONI
SIZE
ABMESSUNGEN

GRUPPO GROUP BAUREIHE	TIPO TYPE TYP	A		B	
		mm	in	mm	in
1	19	38,7	1,524	19,4	0,762
	24	38,7	1,524	19,4	0,762
	31	38,7	1,524	19,4	0,762
	36	45,35	1,785	22,7	0,893
	44	45,35	1,785	22,7	0,893
	48	45,35	1,785	22,7	0,893
	60	56,05	2,207	28,0	1,103
	70	56,05	2,207	28,0	1,103
	80	56,05	2,207	28,0	1,103

HPLDF.1 **VERSIONE CON VALVOLE**
VERSION WITH VALVES
VERSION MIT VENTILEN

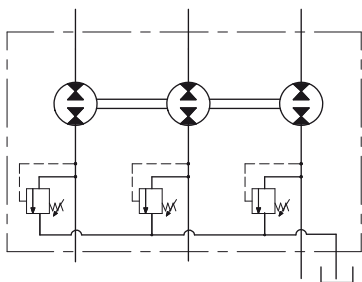
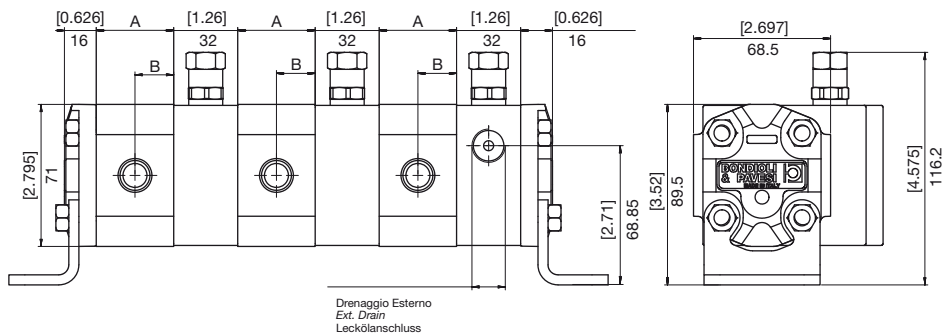

DIMENSIONI
SIZE
ABMESSUNGEN

GRUPPO GROUP BAUREIHE	TIPO TYPE TYP	A		B	
		mm	in	mm	in
1	19	38,7	1,524	19,4	0,762
	24	38,7	1,524	19,4	0,762
	31	38,7	1,524	19,4	0,762
	36	45,35	1,785	22,7	0,893
	44	45,35	1,785	22,7	0,893
	48	45,35	1,785	22,7	0,893
	60	56,05	2,207	28,0	1,103
	70	56,05	2,207	28,0	1,103
	80	56,05	2,207	28,0	1,103



HPLDF.1

VERSIONE CON VALVOLE ENTRATA UNICA
VERSION WITH VALVES, SINGLE INLET
VERSION MIT VENILEN UND EINZIGEM EINGANG

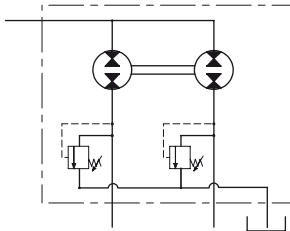
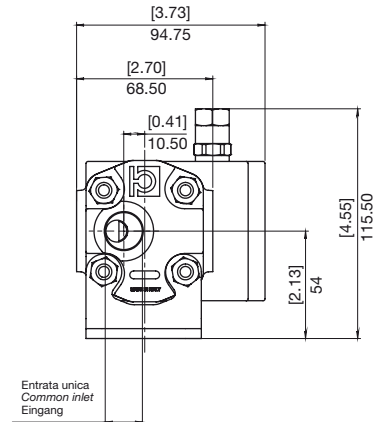
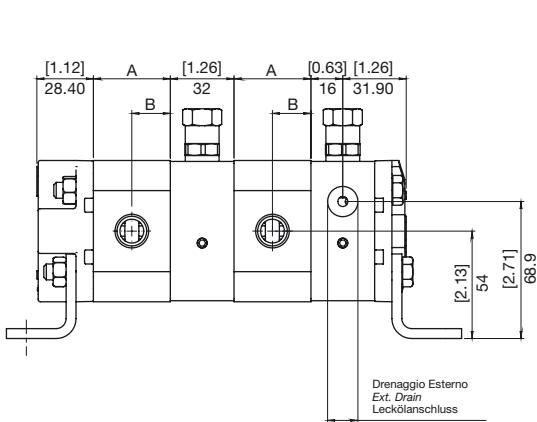

DIMENSIONI
SIZE
ABMESSUNGEN

GRUPPO GROUP BAUREIHE	TIPO TYPE TYP	A		B	
		mm	in	mm	in
1	19	38,7	1,524	19,4	0,762
	24	38,7	1,524	19,4	0,762
	31	38,7	1,524	19,4	0,762
	36	45,35	1,785	22,7	0,893
	44	45,35	1,785	22,7	0,893
	48	45,35	1,785	22,7	0,893
	60	56,05	2,207	28,0	1,103
	70	56,05	2,207	28,0	1,103
	80	56,05	2,207	28,0	1,103

HPLDF.2 CONFIGURAZIONE STANDARD
 STANDARD CONFIGURATION
 STANDARDKONFIGURATION

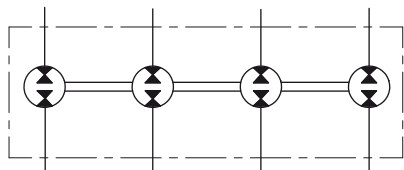
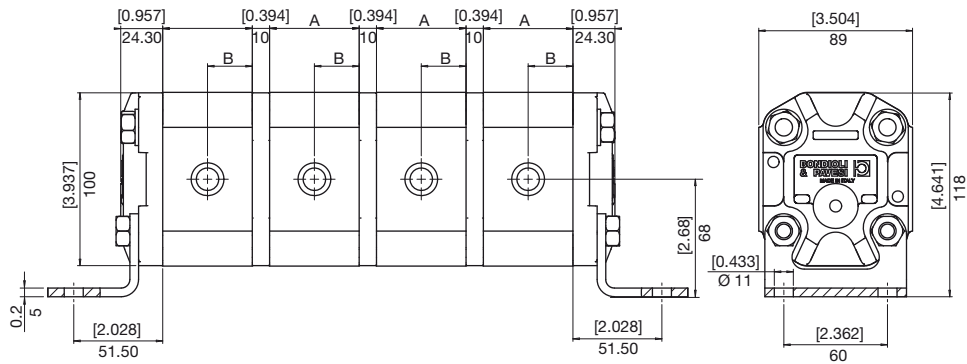

DIMENSIONI
SIZE
ABMESSUNGEN

GRUPPO GROUP BAUREIHE	TIPO TYPE TYP	A		B	
		mm	in	mm	in
2	05	49,15	1,935	24,6	0,968
	06	51,85	2,041	25,9	1,021
	08	56,35	2,219	28,2	1,109
	11	60,85	2,396	30,4	1,198
	14	67,25	2,648	33,6	1,324
	17	71,75	2,825	35,9	1,412
	20	76,25	3,002	38,1	1,501
26	88,55	3,486	44,3	1,743	



HPLDF.2

CONFIGURAZIONE ENTRATA UNICA COPERCHIO
COVER SINGLE INLET CONFIGURATION
DECKEL KONFIGURATION MIT EINZIGEM EINGANG

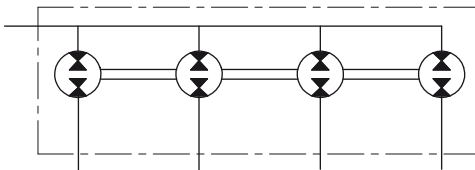
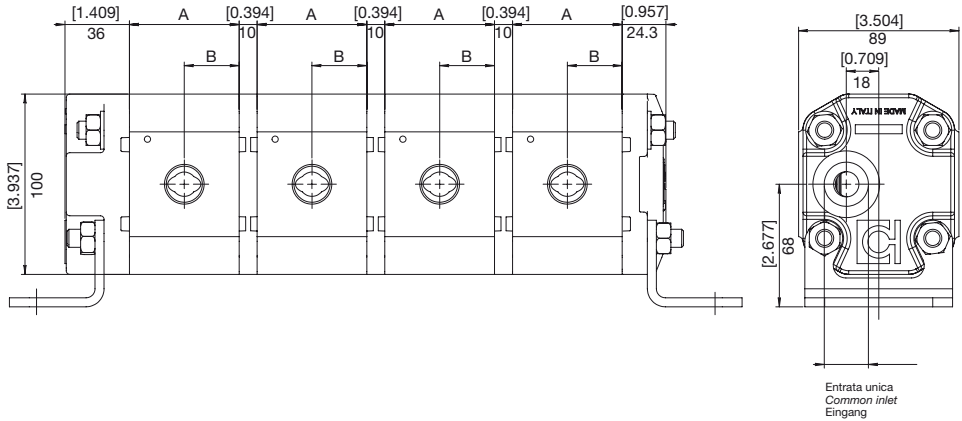

DIMENSIONI
SIZE
ABMESSUNGEN

GRUPPO GROUP BAUREIHE	TIPO TYPE TYP	A		B	
		mm	in	mm	in
2	05	49,15	1,935	24,6	0,968
	06	51,85	2,041	25,9	1,021
	08	56,35	2,219	28,2	1,109
	11	60,85	2,396	30,4	1,198
	14	67,25	2,648	33,6	1,324
	17	71,75	2,825	35,9	1,412
	20	76,25	3,002	38,1	1,501
	26	88,55	3,486	44,3	1,743

HPLDF.2

CONFIGURAZIONE ENTRATA UNICA CORPO
 BODY SINGLE INLET CONFIGURATION
 KÖRPER KONFIGURATION MIT EINZIGEM EINGANG

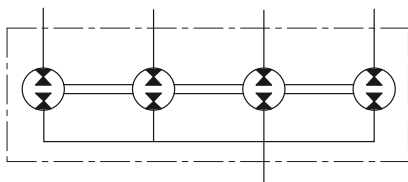
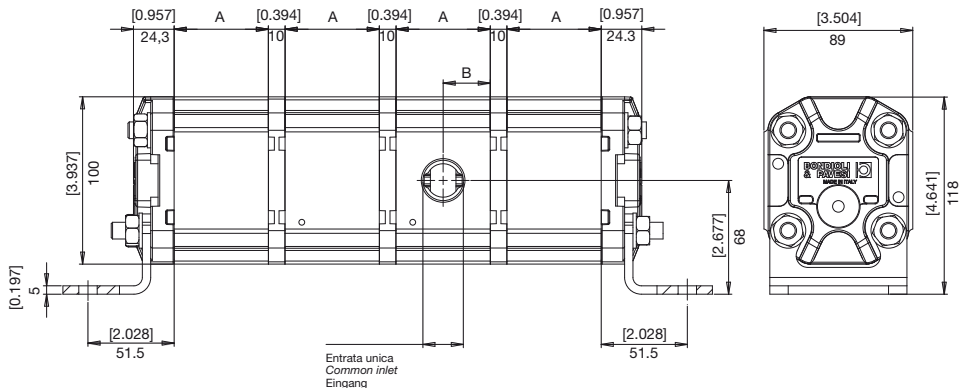

DIMENSIONI
 SIZE
 ABMESSUNGEN

GRUPPO GROUP BAUREIHE	TIPO TYPE TYP	A		B	
		mm	in	mm	in
2	05	49,15	1,935	24,6	0,968
	06	51,85	2,041	25,9	1,021
	08	56,35	2,219	28,2	1,109
	11	60,85	2,396	30,4	1,198
	14	67,25	2,648	33,6	1,324
	17	71,75	2,825	35,9	1,412
	20	76,25	3,002	38,1	1,501
26	88,55	3,486	44,3	1,743	



DIVISORI DI FLUSSO
FLOW DIVIDERS
MENGENTEILER

HPLDF..

HPLDF.2

VERSIONE CON VALVOLE
VERSION WITH VALVES
VERSION MIT VENTILEN

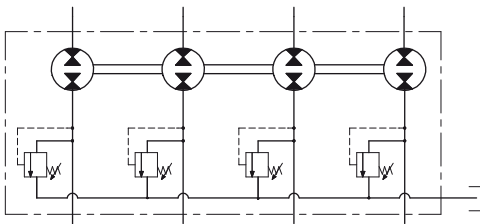
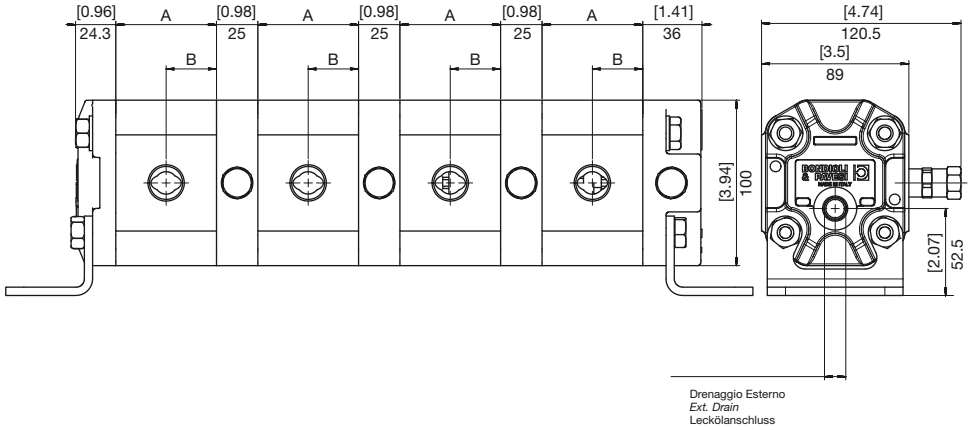

DIMENSIONI
SIZE
ABMESSUNGEN

GRUPPO GROUP BAUREIHE	TIPO TYPE TYP	A		B	
		mm	in	mm	in
2	05	49,15	1,935	24,6	0,968
	06	51,85	2,041	25,9	1,021
	08	56,35	2,219	28,2	1,109
	11	60,85	2,396	30,4	1,198
	14	67,25	2,648	33,6	1,324
	17	71,75	2,825	35,9	1,412
	20	76,25	3,002	38,1	1,501
	26	88,55	3,486	44,3	1,743

HPLDF.2

VERSIONE CON VALVOLE ENTRATA UNICA
VERSION WITH VALVES, SINGLE INLET
VERSION MIT VENTILEN UND EINZIGEM EINGANG

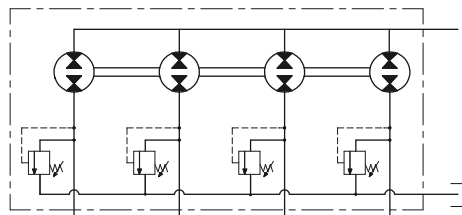
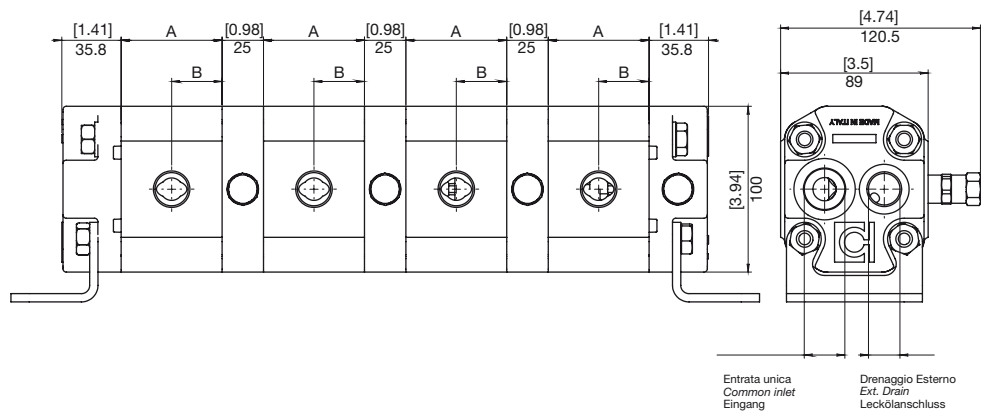

DIMENSIONI
SIZE
ABMESSUNGEN

GRUPPO GROUP BAUREIHE	TIPO TYPE TYP	A		B	
		mm	in	mm	in
2	05	49,15	1,935	24,6	0,968
	06	51,85	2,041	25,9	1,021
	08	56,35	2,219	28,2	1,109
	11	60,85	2,396	30,4	1,198
	14	67,25	2,648	33,6	1,324
	17	71,75	2,825	35,9	1,412
	20	76,25	3,002	38,1	1,501
26	88,55	3,486	44,3	1,743	

HPLDF.3 CONFIGURAZIONE STANDARD
 STANDARD CONFIGURATION
 STANDARDKONFIGURATION

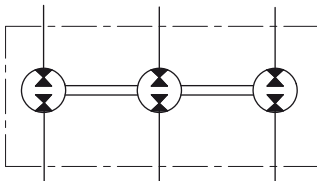
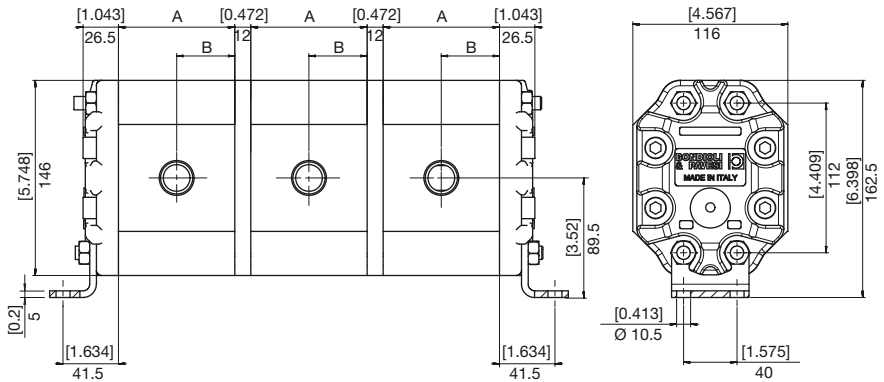

DIMENSIONI
SIZE
ABMESSUNGEN

GRUPPO GROUP BAUREIHE	TIPO TYPE TYP	A		B	
		mm	in	mm	in
3	22	81,07	3,192	40,5	1,594
	26	84,07	3,310	42,0	1,654
	31	87,07	3,428	43,5	1,714
	36	91,07	3,585	45,5	1,793
	41	95,07	3,743	47,5	1,870
	47	98,07	3,861	49,0	1,929
	51	101,07	3,979	50,5	1,990

HPLDF.3

CONFIGURAZIONE ENTRATA UNICA
SINGLE INLET CONFIGURATION
KONFIGURATION MIT EINZIGEM EINGANG

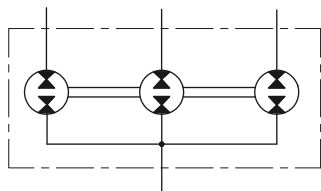
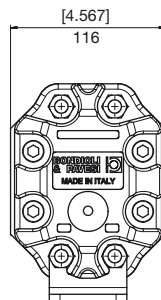
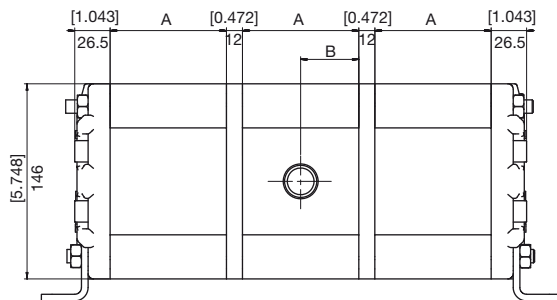

DIMENSIONI
SIZE
ABMESSUNGEN

GRUPPO GROUP BAUREIHE	TIPO TYPE TYP	A		B	
		mm	in	mm	in
3	22	81,07	3,192	40,5	1,594
	26	84,07	3,310	42,0	1,654
	31	87,07	3,428	43,5	1,714
	36	91,07	3,585	45,5	1,793
	41	95,07	3,743	47,5	1,870
	47	98,07	3,861	49,0	1,929
	51	101,07	3,979	50,5	1,990



**BOCCHIE
PORTS
ANSCHLÜSSE**

HPLDF..

E LATERALE
LATERAL
SEITLICH

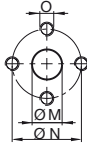

TIPO TYPE TYP	M		N		O	
	mm	in	mm	in		Nm
E3	13	0,51	30	1,18	M6	10
E5	20	0,79	40	1,57	M8	15
E7	27	1,34	51	2,01	M10	30

G LATERALE
LATERAL
SEITLICH
T POSTERIORE
REAR
HINTEN

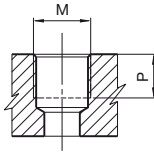

TIPO TYPE TYP	M		P	
		Nm	mm	in
G3	3/8" GAS BSPP	38	12	0,47
G4	1/2" GAS BSPP	50	16	0,63
G6	3/4" GAS BSPP	90	19	0,75
G7	1" GAS BSPP	130	21	0,83
T4	1/2" GAS BSPP	50	16	0,63
T6	3/4" GAS BSPP	70	19	0,75

U LATERALE
LATERAL
SEITLICH
C POSTERIORE
REAR
HINTEN

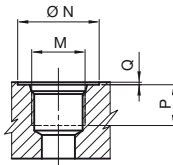

TIPO TYPE TYP	DIMENSIONE SIZE GRÖSSE	N		P		Q		M	
		mm	in	mm	in	mm	in		Nm
U3	3/8"	25	0,98	13	0,3	0,3	0,01	9/16"-18 UNF	25
U4	1/2"	30	1,18	15	0,3	0,3	0,01	3/4"-16 UNF	47
U5	5/8"	34	1,34	17	0,67	0,3	0,01	7/8"-14 UNF	70
U6	3/4"	41	1,61	19	0,75	0,3	0,01	1-1/16"-12 UNF	90
U7	1"	49	1,93	19	0,75	0,3	0,01	1-5/16"-12 UNF	130
C5	5/8"	34	1,34	17	0,67	0,3	0,01	7/8"-14 UNF	70
C6	3/4"	41	1,61	19	0,75	0,3	0,01	1-1/16"-12 UNF	70

HPL

DF

2

2

11

G4 G4

B

ST

--

SERIE
SERIES
SERIE

PRODOTTO
PRODUCT
PRODUKT

DF - Divisori di flusso
Flow dividers
Mengenteiler

2 - 3 - 4 - 5 - 6

N° degli Stadi
N° Stage
N° Stufen

GRUPPO
GROUP
BAUGRÖSSE

1 - 2 - 3

CILINDRATA
DISPLACEMENT
FÖRDERVOLUMEN

HPLDF.1	HPLDF.2	HPLDF.3
19 - 1,90	05 - 4,50	22 - 21,50
24 - 2,53	06 - 6,00	26 - 26,00
31 - 3,17	08 - 8,50	31 - 30,50
36 - 3,73	11 - 11,00	36 - 36,00
44 - 4,35	14 - 14,50	41 - 41,50
48 - 4,97	17 - 17,00	47 - 46,50
60 - 6,08	20 - 19,50	51 - 50,50
70 - 7,00	26 - 26,00	
80 - 7,87		

SET VALVOLE
VALVE SETTING
VENTILEINSTELLUNG
(bar)

COPERCHI - COVERS - DECKEL
ST - Standard
SG - Versione in ghisa (solo HPLDF.3)
Cast iron version (only HPLDF.3)
Gussversion (nur HPLDF.3)
VE - Con valvole (Vedi sez. valvole)
With valves (See valves section)
Mit Ventilen (siehe Ventile Abschnitt)

GUARNIZIONI
SEALS
DICHTUNGEN

B - NBR

V - Viton

BOCCHE - PORT - ANSCHLÜSSE

HPLDF.1 - BOCCHE STD - STANDARD PORT - STANDARD ANSCHLÜSSE

CILINDRATA - DISPLACEMENT - FÖRDER-/SCHLUCKVOLUMEN
1,9.....4,8

IN/OUT	DRAIN	IN/OUT	DRAIN
E3 E3	G3	E3 E3	G3
G3 G3	G3	G4 G4	G3
U3 U3	U3	U4 U4	U3

ASPIRAZIONE UNICA COPERCHIO - COVER COMMON INLET - EINGANG DECKEL

T4 G3	G3	T4 G4	G3
C5 U3	U3	U5 U4	U3

ASPIRAZIONE UNICA CORPO - BODY COMMON INLET - EINGANG GEHÄUSE

G4 G3	G3	G6 G4	G3
U4 U3	U3	U5 U4	U3

HPLDF.2 - BOCCHE STD - STANDARD PORT - STANDARD ANSCHLÜSSE

CILINDRATA - DISPLACEMENT - FÖRDER-/SCHLUCKVOLUMEN
5.....11

IN/OUT	DRAIN	IN/OUT	DRAIN	IN/OUT	DRAIN
E3 E3	G4	E5 E5	G4	E5 E5	G4
G4 G4	G4	G6 G6	G4	G6 G6	G4
U5 U5	U4	U6 U6	U4	U6 U6	U4

ASPIRAZIONE UNICA COPERCHIO - COVER COMMON INLET - EINGANG DECKEL

T6 G4	G4	T6 G4	G4	T6 G4	G4
C6 U5	U4	C6 U5	U4	C6 U5	U4

ASPIRAZIONE UNICA CORPO - BODY COMMON INLET - EINGANG GEHÄUSE

G6 G4	G4	G6 G4	G4	G7 G6	G4
U6 U4	U4	U6 U5	U4	U7 U6	U4

HPLDF.3 - BOCCHE STD - STANDARD PORT - STANDARD ANSCHLÜSSE

CILINDRATA - DISPLACEMENT - FÖRDER-/SCHLUCKVOLUMEN
22.....31

IN/OUT	IN/OUT
E5 E5	E7 E7
G6 G6	G7 G7
U6 U6	U7 U7

ASPIRAZIONE UNICA CORPO - BODY COMMON INLET - EINGANG GEHÄUSE

G7 G6	G8 G7
U7 U6	U8 U7

RACCORDI A GOMITO
UNION ELBOW
WINKELVERBINDUNGEN

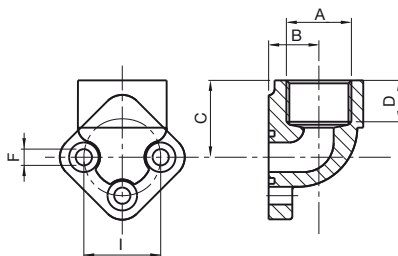

TIPO TYPE TYP	DESCRIZIONE DESCRIPTION BEZEICHNUNG	A		B		C		D		I		F	
		mm	in	mm	in	mm	in	mm	in	mm	in	mm	in
HPL5767E0G31R	GR.RG 26x12 G3/8"	3/8"	16,0	0,63	26	1,02	14	0,56	26	1,02	5,50	0,22	
HPL5767E0G41R	GR.RG 26x12 G1/2"	1/2"	16,0	0,63	26	1,02	14	0,56	26	1,02	5,50	0,22	
HPL5767E3G31R	GR.RG 30x13.5 G3/8"	3/8"	17,5	0,69	26	1,02	14	0,56	30	1,18	6,50	0,26	
HPL5767E3G41R	GR.RG 30x13.5 G1/2"	1/2"	17,5	0,69	26	1,02	14	0,56	30	1,18	6,50	0,26	
HPL5767E4G61R	GR.RG 40x20 G3/4"	3/4"	21,0	0,82	36	1,42	16	0,60	40	1,58	8,50	0,33	
HPL5767E7G71R	GR.RG 51x27 G1"	1"	27,0	1,06	43	1,70	21	0,80	51	2,00	10,5	4,13	
HPL5767E8G81R	GR.RG 62x34 G1 1/4"	1 1/4"	34,5	1,36	55	2,17	27	1,06	62	2,45	10,5	4,13	
HPL5767E4G41R	GR.RG 40x20 G1/2"	1/2"	21,0	0,83	36	1,42	16	0,63	40	1,58	8,50	0,33	
HPL5767E0M41R	GR.RG 26x12 M18x1.5	18X1.5	17,5	0,69	26	1,02	14	0,56	26	1,02	5,50	0,22	
HPL5767E3M41R	GR.RG 30x13.5 M18x1.5	18X1.5	17,5	0,69	26	1,02	14	0,56	30	1,18	6,50	0,26	

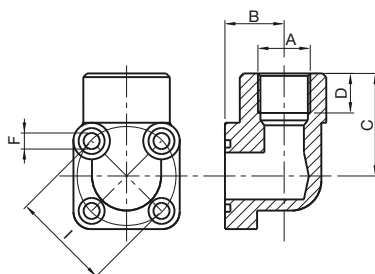

TIPO TYPE TYP	DESCRIZIONE DESCRIPTION BEZEICHNUNG	A		B		C		D		I		F	
		mm	in	mm	in	mm	in	mm	in	mm	in	mm	in
HPL5767X3G31R	GR.R.GB 30x13 G3/8"	3/8"	18	0,70	40,0	1,58	16	0,63	30	1,18	6,5	0,22	
HPL5767X3G41R	GR.R.GB 30x13 G1/2"	1/2"	18	0,70	40,0	1,58	16	0,63	30	1,18	6,5	0,22	
HPL5767X4G31R	GR.R.GB 35x13 G3/8"	3/8"	18	0,70	40,0	1,58	16	0,63	35	1,38	6,5	0,22	
HPL5767X4G41R	GR.R.GB 35x13 G1/2"	1/2"	18	0,70	40,0	1,58	16	0,63	35	1,38	6,5	0,22	
HPL5767X6G61R	GR.R.GB 40x19 G3/4"	3/4"	24	0,95	41,5	1,63	16	0,63	40	1,58	6,5	0,22	
HPL5767X6G41R	GR.R.GB 40x19 G1/2"	1/2"	24	0,95	41,5	1,63	16	0,63	40	1,58	6,5	0,22	
HPL5767X3M41R	GR.R.GB 30x13 M18x1.5	18X1.5	18	0,70	40,0	1,58	16	0,63	30	1,18	6,5	0,22	

RACCORDI DIRITTI
STRAIGHT UNION
GERADE VERBINDUNGEN

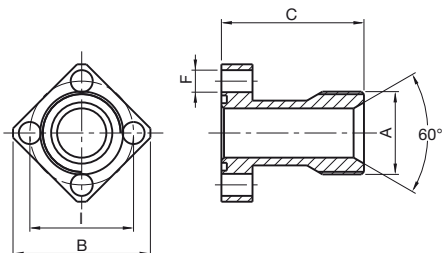

TIPO TYPE TYP	DESCRIZIONE DESCRIPTION BEZEICHNUNG	A	B		C		I		F	
			mm	in	mm	in	mm	in	mm	in
HPL5767E3G42R	GR.RD 30x13.5 (1/2")	1/2"	46	1,81	55	2,16	30	1,18	6,5	0,26
HPL5767E5G42R	GR.RD 40x20 (3/4")	3/4"	53	2,09	40	1,58	40	1,58	8,5	0,33
HPL5767E7G42R	GR.RD 51x27 (1")	1"	73	2,88	55	2,17	51	2,00	10,5	4,13
HPL5767E8G42R	GR.RD 62x34 (1 1/4")	1 1/4"	86	3,39	70	2,76	62	2,45	10,5	4,13
HPL5767E0M42R	GR.RD 26x12 M18x1.5	18X1.5	46	1,81	35	1,38	26	1,81	6,5	0,26

NOTE: I raccordi vengono forniti completi di viti, rondelle e guarnizioni OR.

NOTE: Connectors are supplied complete with bolts, washers and O-rings.

BEMERKUNG: Die Verbindungen werden komplett mit Schrauben, U-Scheiben und O-Ringen geliefert.

KIT GUARNIZIONI
SEALS KIT
DICHTUNGSSÄTZE

TIPO TYPE TYP	DESCRIZIONE	DESCRIPTION	BEZEICHNUNG
HPL48670PAUNB00R05	GRUPPO 05 POMPA NBR	GROUP 05 NBR PUMP/MOTOR	BAUGRÖSSE 5 NBR PUMPE UND MOTOR
HPL48671PAUNB00R05	GRUPPO 1 POMPA NBR	GROUP 1 PUMP NBR	BAUGRÖSSE 1 NBR PUMPE
HPL48671PAUNV00R05	GRUPPO 1 POMPA VITON	GROUP 1 PUMP VITON	BAUGRÖSSE 1 VITON PUMPE
HPL48671PAUNB01R05	GRUPPO 1 BOSCH POMPA NBR	GROUP 1 BOSCH NBR	BAUGRÖSSE 1 BOSCH NBR PUMPE
HPL48671MARVB01R05	GRUPPO 1 BOSCH MOTORE BID.	GROUP 1 BOSCH MOTOR NBR	BAUGRÖSSE 1 BOSCH NBR MOTOR
HPL48671MARVB00R05	GRUPPO 1 MOTORE BID. NBR	GROUP 1 MOTOR NBR	BAUGRÖSSE 1 NBR MOTOR
HPL48672PAUNB03R05	GRUPPO 2 POMPA NBR	GROUP 2 PUMP NBR	BAUGRÖSSE 2 NBR PUMPE
HPL48672MARVB00R05	GRUPPO 2 MOTORE NBR	GROUP 2 MOTOR NBR	BAUGRÖSSE 2 NBR MOTOR
HPL48672PAUNV02R05	GRUPPO 2 POMPA VITON	GROUP 2 PUMP VITON	BAUGRÖSSE 2 VITON PUMPE
HPL48672MARVV00R05	GRUPPO 2 MOTORE VITON	GROUP 2 MOTOR VITON	BAUGRÖSSE 2 VITON MOTOR
HPL48673PAUNB00R05	GRUPPO 3/4 POMPA NBR	GROUP 3/4 PUMP NBR	BAUGRÖSSE 3/4 NBR PUMPE
HPL48673MARVB00R05	GRUPPO 3/4 MOTORE NBR	GROUP 3/4 MOTOR NBR	BAUGRÖSSE 3/4 NBR MOTOR
HPL48673PAUNV00R05	GRUPPO 3/4 POMPA VITON	GROUP 3/4 PUMP VITON	BAUGRÖSSE 3/4 VITON PUMPE
HPL48673DFRVB01R05	KIT GUARNIZIONI DIVISORE 5ST.GR.3 NBR	INDEXING GEAR GASKET KIT 5ST.GR.3 NBR	BAUSATZ DICHTUNGEN TEILER 5ST.GR.3 NBR



TIPO TYPE TYP	DESCRIZIONE	DESCRIPTION	BEZEICHNUNG
HPL21000007010R05	GR.1 SEMIG.(25X22 Z=14) TC C1-C2	<i>GR.1 HALF HUB (25X22 Z=14) TC C1-C2</i>	GR.1 HALBKUP (25X22 Z=14) TC C1-C2
HPL00020045140R05	GR.1 GIUNTO PER ALBERO K	<i>GR.1 HUB FOR SHAFT K</i>	GR.1 KUPPLUNG FÜR WELLE K
HPL21000008010R05	GR.2 SEMIG.(28X25 Z=15) TC C3-C4	<i>GR.2 HALF HUB (28X25 Z=15) TC C3-C4</i>	GR.2 HALBKUP (28X25 Z=15) TC C3-C4
HPL21000010010R05	GR.2 SEMIG.(32X28 Z=17) TC B1	<i>GR.2 HALF HUB (32X28 Z=17) TC B1</i>	GR.2 HALBKUP (32X28 Z=17) TC B1
HPL21000002010R05	GR.2 SEMIG.(25X22 Z=14) TC C5-C6	<i>GR.2 HALF HUB (25X22 Z=14) TC C5-C6</i>	GR.2 HALBKUP (25X22 Z=14) TC C5-C6
HPL00020045240R05	GR.2 GIUNTO PER ALBERO Z	<i>GR.2 HUB FOR SHAFT Z</i>	GR.2 KUPPLUNG FÜR WELLE Z
HPL21000003010R05	GR.3 SEMIG.(35X31 Z=18) TC C7-C8	<i>GR.3 HALF HUB (35X31 Z=18) TC C7-C8</i>	GR.3 HALBKUP (35X31 Z=18) TC C7-C8
HPL21000004010R05	GR.4 SEMIG.(40X36 Z=20) TC C9-C0	<i>GR.4 HALF HUB (40X36 Z=20) TC C9-C0</i>	GR.4 HALBKUP (40X36 Z=20) TC C9-C0